

Assembly Instructions

Hybrid 6'x4' - Merged Glazing

Approx. Dim.

130L x 185W x 209H cm / 51.2L" x 72.8W" x 82.3H"

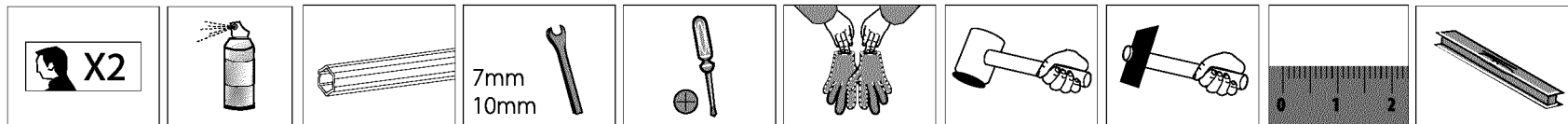

After Sale Service

Email: customer.service@palram.com

USA 877-627-8476
Canada 1 800-866-5749

England 01302-380775
Germany 0180-522-8778

France 0169-791-094
International +972 4-848-6942

www.palramapplications.com

IMPORTANT

Please read these instructions carefully before you start to assemble this greenhouse.
Keep these instructions in a safe place for future reference.

⇒ Customer Service

For assistance with assembly or for replacement parts – please log onto our website or call our service line (number is on the title page).

Additional information can be found at our website: www.palamapplications.com

⇒ Safety Advice

- It is of utmost importance to assemble all of the parts according to the directions. Do not skip any step.
- We strongly recommend using work gloves during assembly.
- Always wear shoes and safety goggles when working with extruded aluminium.
- If using a step ladder or power tools ensure that you follow the manufacturer's safety advice.
- Do not touch overhead power cables with the aluminium profiles.
- Do not attempt to assemble the greenhouse in windy or wet conditions.
- Dispose of all plastic bags safely keep them out of reach of small children.
- Keep children away from the assembly area.
- Do not lean against or push the greenhouse during construction.
- Do not position your greenhouse in an area exposed to excessive wind.
- Do not attempt to assemble this greenhouse if you are tired, have taken drugs or alcohol or if you are prone to dizzy spell.
- Hot items such as recently used grills, blowtorches etc. must not be stored in the greenhouse. Ensure there are no hidden pipes or cables in the ground before inserting the pegs.
- This product is designed to use as greenhouse only.

⇒ Care & Maintenance

When your greenhouse needs to be cleaned, use a mild detergent solution and rinse with cold clean water. DO NOT use acetone, abrasive cleaners or other special detergents to clean the clear panels. It is recommended to check periodically that roof panels caps (plastic part 329 & profile 981) are set in place.

⇒ Tools & Equipment

- Tape measure
- Work gloves
- Lubricant
- Phillips head screwdriver
- Step ladder
- Drill bit

- Large hammer
- Spanner
- T001 - Special tool for Screws 411 and nuts 412



⇒ Before Assembly

This is a multi-part assembly best achieved by two people. Allow at least half a day for assembly process.

Selecting a site - the greenhouse must be , positioned and fixed on a flat level surface.

Choose a sunny position away from overhanging trees.

We are strongly recommend to fix your greenhouse directly to a solid concrete foundation. When doing that use the pre drilled holes in the metal base supplied.

Take out all components parts of the packages. Sort the parts and check against the contents parts list.

During assembly parts should be laid out close at hand. Keep all small parts (screws etc.) in a bowl so they do not get lost.

In purpose to facilitate parts' identification and assembly process, all-positioned profiles are used in this greenhouse. As a result some apertures in the profiles are not used during assembly.

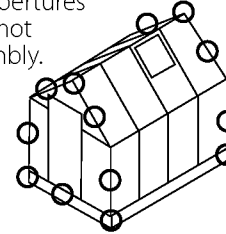

⇒ During Assembly

Carry out the assembly steps in the order set out in the instructions.

You may use Silicon lubricant spray in order to help you slide the profiles on the connectors. Do not spray the Polycarbonate panels. Use the rubber mallet if necessary.



Step 1: Make sure the base is square by measuring the diagonals and level by using a spirit level.

Step 4: Part A994, A995 are in the back of the greenhouse. Fixing them determines the front side of the greenhouse.

Steps 7, 10: The oval hole in the crossbars A256 should always be assembled to the base of the greenhouse.

Door assembly (Steps 8, 43-49)

Door can be installed as a left hand door or right hand door to your decision. These instructions show a right hand door assembly.

Step 8: determines door direction door post 987 is where door hinges will be located.

Steps 43-49: Door assembly should be done according to this decision.

Step 28: Decide on the window's location before assembly. Window can be installed in one of the indicated options.

Step 42 : In case the window is not closed properly, please release the screws, adjust the profile and tighten the screw.

Step 51: Firmly connect the greenhouse to a level final position immediately after completion of the assembly.

Tighten all screws when completing assembly.

Screws 411 and nuts 412 are used throughout the assembly process.

- Screws 411 are to be assembled from the outside and nuts 412 from the inside of the greenhouse.
- Do not fasten screws and nuts (411 & 412) more than 2-3 turns only. Do not tighten them until completion of the panels' assembly, if not specified otherwise.
- However, in some steps, temporary tightening of a few screws may be needed to prevent a profile from falling till it will be fully connected in the next steps.



WICHTIG

Bitte lesen Sie diese Anweisungen sorgfältig durch, bevor Sie mit dem Aufbau des Gewächshauses beginnen.
Heben Sie diese Anweisungen an einem sicheren Ort auf, um später auf sie zurückgreifen zu können.

⇒ **Kundendienst**

Für Hilfe bei dem Aufbau oder für Ersatzteile – können Sie sich entweder auf unserer Webseite einloggen oder unseren Kundendienst anrufen (die Nummer steht auf der Titelseite).

Weitere Informationen finden Sie auf unserer Webseite: www.palramapplications.com

⇒ **Sicherheitshinweise**

- Es ist von grösster Wichtigkeit, alle Teile genau gemäss den Anweisungen zusammenzubauen. Lassen Sie keinen Schritt aus.
- Wir empfehlen wärmstens, während des Aufbaus Arbeitshandschuhe zu tragen.
- Tragen Sie immer Schuhe und eine Schutzbrille, wenn Sie mit stranggepresstem Aluminium arbeiten.
- Wenn Sie eine Stufenleiter oder Elektrowerkzeuge benutzen, achten Sie darauf, die Sicherheitshinweise des Herstellers zu befolgen.
- Berühren Sie mit den Aluminiumprofilen keine Oberleitungen.
- Versuchen Sie nicht, das Gewächshaus bei windigem oder regnerischem Wetter zusammenzubauen.
- Entsorgen Sie alle Plastiktüten sicher und bewahren sie ausserhalb der Reichweite von kleinen Kindern auf.
- Halten Sie Kinder vom Aufbaubereich fern.
- Während des Aufbaus sollten Sie sich nicht gegen das Gewächshaus lehnen oder es drücken.
- Bauen Sie Ihr Gewächshaus nicht an Orten mit hoher Windbelastung auf.
- Versuchen Sie nicht, dieses Gewächshaus aufzubauen wenn Sie müde sind, unter dem Einfluss von Drogen oder Alkohol stehen oder zu Schwindelanfällen neigen.
- Heisse Geräte wie kürzlich benutzte Grills, Schneidbrenner usw. dürfen nicht im Gewächshaus gelagert werden. Vergewissern Sie sich vor Einsetzen der Pflöcke, dass sich keine versteckten Rohre oder Kabel im Boden befinden.
- Dieses Produkt ist nur für den Einsatz als Gewächshaus geeignet.

⇒ **Pflege und Wartung**

Benutzen Sie eine milde Reinigungslösung für die Reinigung Ihres Gewächshauses und spülen es danach mit kaltem, sauberem Wasser ab. Benutzen Sie AUF KEINEN FALL Azeton, Scheuermittel oder andere spezielle Reinigungsmittel, um die klaren Platten zu reinigen.

⇒ **Werkzeuge & Ausrüstung**

- Maßband
- Arbeitshandschuhe
- Plastik- oder Gummihammer
- Schmiermittel
- Kreuzschlitzschraubenzieher
- Stufenleiter
- Bohrer

- Grosser Hamme
- Schere
- Schlüssel
- T001

⇒ **Vor dem Zusammenbau**

Diese ist eine Mehrteilige Montage. Der Zusammenbau der Teile wird am besten von zwei Leuten bewältigt. Rechnen Sie mit mindestens einem halben Tag für den Zusammenbau.

Wahl des Standorts - das Gewächshaus muss auf einem flachen ebenen Untergrund aufgebaut und fixiert werden. Wählen Sie eine sonnige Stelle ohne überhängende Bäume.

Wir empfehlen Ihnen sehr Ihr Gewächshaus direkt auf einem soliden Betonfundament zu befestigen. Dazu sollten Sie die vorgebohrten Löcher in der gelieferten Metallbasis benutzen.

Nehmen Sie alle Teile aus der Verpackung. Sortieren Sie die Teile und überprüfen Sie sie mit Hilfe der Inhaltsliste auf Vollständigkeit.

Während des Aufbaus sollten die Teile in Ihrer Nähe auf dem Boden ausgelegt werden. Bewahren Sie alle kleinen Teile (Schrauben usw.) in einer Schüssel auf, sodass sie nicht verloren gehen.

Um die Identifikation der Teile zu erleichtern und um die Montage zu vereinfachen, werden gleiche Profile in verschiedene Positionen eingebaut, sodass bei manchen Positionen einige Löcher dieser Profile während der Montage nicht verwendet werden.

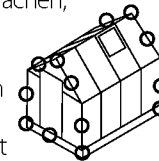

Schrauben 411 and Muttern 412 werden während des gesamten Aufbauvorgangs benutzt.

- Schrauben 411 werden von der Aussenseite des Gewächshauses eingesetzt und Muttern 412 von der Innenseite.
- Ziehen Sie die Schrauben und Muttern (411 und 412) nicht mit mehr als 2 – 3 Umdrehungen fest. Ziehen Sie sie erst nach Beendigung der Verglasung weiter fest, falls dies nicht ausdrücklich anders festgelegt ist.
- Sie sollten jedoch, in einigen Schritten, ein paar Schrauben vorübergehend festziehen um ein Profil von Fallen zu verhindern bis es in vollem Umfang in den nächsten Schritten verbunden wird.

⇒ **Während des Zusammenbaus**

Führen Sie den Aufbau in der in den Gebrauchsanweisungen aufgeführten Reihenfolge Schritt per Schritt aus.

Sie können Silikonfett- Spray verwenden, um das Schieben der Profile 924 auf die Anschlüsse zu erleichtern.



Sprühen Sie nicht auf die Polycarbonatplatten. Verwenden Sie den Gummihammer, falls nötig.

Schritt 1: Vergewissern Sie sich, dass die Basis sowohl quadratisch als auch waagrecht ist, indem Sie die Diagonalen messen und die Basis mit einer Wasserwaage prüfen.

Schritt 4: Teil A994, A995 sind in der Rückseite des Gewächshauses und deren Festsetzung bestimmt die Vorderseite des Gewächshauses.

Schritte 7, 10: Das ovale Loch in den Querbalken A256 sollte immer auf die Basis des Gewächshauses montiert werden.

Das Zusammenbauen der Tür (Schritte 8, 43-49)

Die Tür kann nach Ihrer Entscheidung, entweder als eine Tür die sich nach Links öffnen lässt oder als eine Tür die sich nach Recht öffnen lässt, installiert werden. Die beigelegte Bauinstruktionen zeigen einen rechten Türbau.

Schritt 8: Bestimmt die Richtung der Tür Türpost 987 ist wo die Türscharniere gelegt werden.

Schritte 43-49: Türzusammenbau sollte gemäß dieser Entscheidung folgen.

Das Zusammenbauen des Fensters (Schritte 28, 42)

Schritt 28: Entscheiden sie über die genaue Lageposition des Fensters vor dessen Einbau. Das Fenster kann in einer der angegebenen Optionen installiert werden.

Schritt 42: Falls das Fenster nicht ordnungsgemäß verschlossen ist, bitte lösen Sie die Schrauben, Stellen Sie die Profile Zu und Befestigen Sie wieder die Schrauben.

Schritt 51: Befestigen Sie das Gewächshaus auf eine endgültige Position direkt nach Beendigung des Aufbaus auf einem waagrechten Untergrund.

Alle Schrauben befestigen nach dem abschluss der Montage

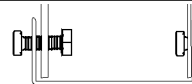

412



411



IMPORTANT !

Veillez lire attentivement ces instructions avant de commencer à monter votre serre.
Conservez ces instructions en lieu sûr pour toute consultation ultérieure.

⇒ **Service clientèle**

Pour toute assistance concernant le montage de la serre ou ses pièces de rechange – veuillez consulter notre site Internet ou appeler notre service technique (dont le numéro de téléphone figure sur la couverture de la brochure).

Pour en savoir plus, n'hésitez pas à visiter notre site Internet : www.palramapplications.com

⇒ **Consignes de sécurité**

- Très important ! Veuillez suivre scrupuleusement les instructions de cette brochure et réaliser les étapes dans l'ordre énoncé.
- Nous recommandons vivement le port de gants de protection pendant le montage.
- Portez toujours des chaussures de travail et des lunettes de protection lorsque vous travaillez des pièces en aluminium extrudé.
- Lors de l'utilisation d'une échelle ou d'outils électriques, assurez-vous de bien suivre les consignes de sécurité du fabricant.
- Veillez à ne pas toucher de câbles aériens avec les profilés en aluminium.
- N'essayez pas de monter la serre s'il y a du vent ou s'il fait humide.
- Jetez tous les sacs en plastique en appliquant les règles de sécurité et maintenez-les hors de portée des jeunes enfants.
- Eloignez les enfants de la zone d'assemblage.
- Ne vous appuyez pas contre la serre et ne la poussez pas pendant le montage.
- Ne positionnez pas la serre dans un endroit trop exposé au vent.
- N'essayez pas de monter la serre si vous êtes fatigué, si vous êtes sous l'effet de drogues, de médicaments ou d'alcool ou encore si vous êtes sujet aux vertiges.
- Les objets chauds tels qu'un barbecue, un chalumeau ou autre article ayant été récemment utilisés, ne doivent pas être rangés dans la serre.
- Avant de planter les piquets, assurez-vous qu'aucun tuyau ni câble n'est enterré à l'endroit sélectionné pour l'installation.
- Ce produit est conçu pour servir de serre exclusivement.

⇒ **Entretien & Maintenance**

Pour nettoyer votre serre, utilisez une solution détergente douce et à rincez à l'eau claire et froide. NE PAS utiliser d'acétone ni de produits nettoyants ou autres détergents spéciaux pour nettoyer les panneaux clairs. Il est recommandé de vérifier régulièrement que les couvre-joints des panneaux du toit sont bien en place (pièces en plastique 329 & profilé 981).

⇒ **Outils & Equipement**

- Mètre (ruban)
- Gants de travail
- Lubrifiant
- Tournevis cruciforme (Philips)
- Escabeau
- Perceuse
- Grand marteau
- Clé à écrous
- T001 – outil spécial pour vis 411 et écrous 412

⇒ **Avant le montage**

Il s'agit d'un assemblage à pièces multiples qu'il est préférable de réaliser à deux personnes et auquel il faut consacrer au moins une demi-journée.

Sélection du site – la serre doit être montée et fixée sur une surface plane.

Choisissez un emplacement ensoleillé et éloigné d'éventuels arbres susceptibles de la surplomber.

Nous recommandons vivement de fixer la serre directement à de solides fondations en béton. Pour ce faire, utilisez les trous déjà percés dans le châssis métallique fourni.

Sortez toutes les pièces de leurs emballages. Triez-les et comparez-les avec la liste des pièces pour vérifier que tout y est.

Lors de l'assemblage, les pièces doivent être disposées à portée de main. Gardez toutes les petites pièces (vis, etc.) dans un récipient pour éviter de les perdre.

Pour faciliter l'identification des pièces et la procédure de montage, les profilés utilisés pour la construction de cette serre sont tous déjà en place. En conséquence, certaines ouvertures des profilés restent inutilisées pendant le montage.

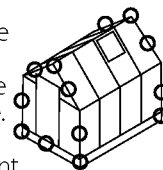
⇒ **Pendant le montage**

Procédez au montage étape par étape, en respectant l'ordre énoncé dans cette brochure.

Vous pouvez utiliser un spray lubrifiant en silicone afin de vous aider à insérer les profilés dans les connecteurs. Veillez à ne pas asperger les panneaux de polycarbonate. Utilisez le maillet en caoutchouc si nécessaire tout en prenant soin de ne pas abîmer les connecteurs en plastique.



Etape 1 : Assurez-vous que le châssis est bien carré en mesurant les diagonales, et vérifiez sa mise à niveau à l'aide d'un niveau à bulle.

Etape 4 : les pièces A994, A995 sont à l'arrière de la serre. Le fait de les fixer détermine également la position de la façade de la serre.

Etapes 7, 10 : L'ouverture ovale des barres transversales A256 doit toujours être placée du côté du châssis de la serre.

Montage de la porte (Etape 8, 43-49) : La porte peut être installée avec la poignée à gauche ou à droite à votre convenance. Ces instructions sont basées sur une installation avec la poignée à droite.

Etape 8 : Déterminez l'orientation de la porte Le montant de porte 987 est celui sur lequel seront fixées les charnières.

Etapes 43-49 : Le montage de la porte doit être réalisé selon la décision prise à ce stade.

Etape 28 : Choisissez l'emplacement de la fenêtre avant le montage, parmi les options indiquées.

Etape 42 : Dans le cas où la fenêtre ne ferme pas correctement, veuillez relâcher les vis, ajuster le profil, et de nouveau resserrer les vis.

Etape 51 : Immédiatement après avoir terminé l'assemblage, fixez solidement la serre en position finale, parfaitement horizontale.

Serrez toutes les vis après avoir achever l'assemblage.

Les vis 411 et écrous 412 servent tout au long de la procédure.

- Les vis 411 se placent à l'extérieur et les écrous 412 à l'intérieur de la serre.
- Ne serrez les vis et écrous (411 & 412) que de 2 à 3 tours, pas plus. Ne les serrez pas tant que l'assemblage n'est pas complètement terminé, sauf indication contraire.
- Cependant, la réalisation de certaines étapes peut nécessiter le serrage provisoire de quelques vis pour empêcher un profilé de tomber en attendant qu'il soit entièrement intégré à l'ensemble de la structure dans les étapes suivantes.



IMPORTANTE

Por favor, lea estas instrucciones cuidadosamente antes de empezar a montar este invernadero.

Mantenga estas instrucciones en un lugar seguro para referencia futura.

⇒ **Servicio de Ayuda al Cliente**

Para obtener ayuda con el montaje o para las piezas de recambio - por favor entre a nuestro sitio web o llame a nuestra línea de servicio (el número está en la página de título). Información adicional se puede encontrar en nuestro sitio web: www.palramapplications.com

⇒ **Consejo de Seguridad**

- Es de suma importancia montar todas las partes de acuerdo con las instrucciones. No se salte ningún paso.
- Recomendamos firmemente el uso de guantes de trabajo durante el montaje.
- Use siempre zapatos y gafas de seguridad al trabajar con aluminio extruido.
- Al usar una escalera plegable o herramientas eléctricas asegúrese de que sigue las instrucciones de seguridad de los fabricantes.
- No toque los cables eléctricos aéreos con los perfiles de aluminio.
- No intente montar el invernadero en días de viento o días con humedad.
- Disponga todas las bolsas plásticas en lugar seguro - guárdelas fuera del alcance de niños.
- Mantenga a los niños fuera del área de montaje.
- No se apoye ni empuje el invernadero durante la construcción.
- No coloque su invernadero en un área expuesta al viento excesivo.
- No intente montar este invernadero si usted está cansado, ha tomado drogas o alcohol o si usted es propenso a ataques de mareo.
- Artículos calientes recientemente usados tales como parrillas, sopletes etc. no deben ser almacenados en el invernadero. Asegúrese de que no haya ninguna tubería o cables ocultos en la tierra antes de insertar las clavijas.
- Este producto es designado a ser usado solamente como invernadero.

⇒ **Cuidados & Mantenimiento**

Cuando su invernadero necesite limpieza, utilice una solución detergente suave y enjuague con agua limpia fría. NO UTILICE acetona, limpiadores abrasivos u otros detergentes especiales para limpiar los paneles. Se recomienda comprobar periódicamente que los paneles del techo > tapones (parte de plástico 329 y perfil 981) están colocados en el lugar.

⇒ **Herramientas & Equipos**

- Cinta métrica
- Broca
- Guantes de trabajo
- Martillo grande
- Lubricante
- Llave inglesa
- Escalera plegable
- Destornillador cabeza de tornillo Phillips
- T001 – Herramienta especial para Tornillos 411 y Tuercas 412

⇒ **Antes del Montaje**

Esto es un montaje de varias partes, mejor ejecutado por dos personas. Dé un plazo de por lo menos medio día para el proceso de montaje.

Seleccionar un sitio – el invernadero debe ser montado, posicionado y fijo en una superficie plana.

Elija un lugar soleado lejos de árboles con ramas colgantes.

Recomendamos firmemente que fije su invernadero directamente a una fundación de concreto sólido. Al hacer esto, utilice los agujeros preperforados en la base de metal proveída.

Saque todas las partes componentes de los paquetes. Clasifique las partes y compruebe contra la lista del contenido.

Durante el montaje las partes deben ser colocadas cerca del alcance de la mano. Guarde todas las piezas pequeñas (tornillos etc.) en un tazón para que no se pierdan.

En el propósito de facilitar la identificación de las partes y el proceso de montaje, todos los perfiles posicionados son usados en este invernadero.

Consecuentemente algunas aberturas en los perfiles no son utilizadas durante el montaje.

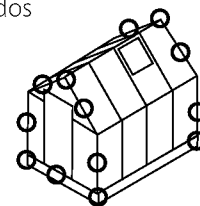
⇒ **Durante el Montaje**

Ejecute los pasos del montaje en el orden indicado en las instrucciones.

Se puede utilizar un lubricante de Silicona en aerosol para facilitar el deslizamiento de los perfiles en los conectores. No aplique el aerosol en los paneles de Policarbonato. Si es necesario, utilice el martillo de goma.



Paso 1: Cerciórese de que la base sea cuadrada midiendo las diagonales y el nivel usando un nivel de burbuja.

Paso 4: Partes A994, A995 están en la parte posterior del invernadero. Fijándolas se determina la parte delantera del invernadero.

Pasos 7, 10: El agujero oval en las barras transversales A256 debe ser siempre montado a la base del invernadero.

Montaje de la puerta (Pasos 8, 43-49)

La puerta puede ser instalada como una puerta de mano izquierda o derecha a su decisión. Estas instrucciones muestran un montaje de puerta de mano derecha.

Paso 8: determina la dirección de la puerta; la jamba 987 de la puerta es donde las bisagras serán ubicadas.

Pasos 43-49: El montaje de la puerta debe ser realizado según esta decisión.

Paso 28: Decida sobre la localización de la ventana antes del montaje. La ventana puede ser instalada en una de las opciones indicadas.

Paso 42: Si la ventana no se cierra correctamente, hay que aflojar los tornillos, ajustar el perfil y volver a apretarlos.

Paso 51: Conecte firmemente el invernadero a un nivel de posición final inmediatamente después de la finalización de la asamblea.

Cuando termine el montaje, apriete bien todos los tornillos.

Los tornillos 411 y las tuercas 412 son usados durante todo el proceso de montaje.

- Los tornillos 411 deben ser montados desde el exterior y las tuercas 412 desde el interior del invernadero.
- No apriete los tornillos y tuercas (411 y 412) más de 2-3 vueltas. No los apriete hasta terminar el montaje de los paneles, a menos que orientado de otra manera.
- Sin embargo, en algunos pasos, el ajuste temporal de algunos tornillos puede ser necesario para evitar que un perfil caiga hasta que sea conectado completamente en los pasos siguientes.



IMPORTANTE

Si invita a leggere attentamente le seguenti istruzioni prima di iniziare il montaggio della serra. Conservare queste istruzioni in luogo sicuro per futuro riferimento.

⇒ Servizio Assistenza Clienti:

Per assistenza nel montaggio o nelle parti di ricambio – si invita a visitare il nostro sito web o a chiamare la nostra linea di servizio (il numero si trova sulla pagina principale).

Ulteriori informazioni sono reperibili sul nostro sito web: www.palramapplications.com

⇒ Nota sulla sicurezza

- È di grande importanza montare le parti secondo le direttive. Non omettere alcuna fase.
- Raccomandiamo caldamente l'uso dei guanti di lavoro durante i lavori di montaggio.
- Indossare sempre scarpe ed occhiali di sicurezza nel maneggiare i profili di alluminio estruso.
- Usando una scala a pioli o utensili elettrici da lavoro, assicurarsi di seguire le disposizioni di sicurezza fornite dal produttore.
- Non toccare cavi elettrici con i profili d'alluminio.
- Non tentare di montare la serra in condizioni atmosferiche ventose o umide.
- Eliminare in modo sicuro tutti i sacchetti di plastica – conservarli fuori della portata dei bambini.
- Tenere i bambini a distanza dall'area di montaggio.
- Non appoggiarsi o spingere la serra durante la sua costruzione.
- Non posizionare la serra in un'area troppo esposta al vento.
- Non tentare di montare la serra in condizioni di stanchezza, dopo aver fatto uso di stupefacenti o alcolici o se si è soggetti ad avere capogiri.
- Oggetti roventi quali griglie o bruciatori per saldature usati di recente ecc., non devono essere introdotti nella serra. Verificare che non vi siano tubi o cavi elettrici sotterranei prima di conficcare i paletti.
- Questo prodotto è stato progettato per essere adibito esclusivamente a serra.

⇒ Cura e manutenzione

Quando la serra deve essere pulita, usare una soluzione detergente neutra e sciacquare con acqua fredda pulita. NON usare acetone, materiali abrasivi o altri detergenti speciali per la pulizia dei pannelli trasparenti. È raccomandabile verificare periodicamente che i coperchi dei pannelli del tetto (parti in plastica 329 e profilo 981) siano montati al loro posto.

⇒ Utensili ed Attrezzature

- Metro
- Guanti da lavoro
- Lubrificante
- Cacciavite con punta a croce
- Scala a pioli
- Punta da trapano
- Martello pesante
- Chiave fissa
- T001 - Utensile speciale per viti 411 e dadi 412



⇒ Prima del montaggio

Il montaggio delle parti dovrà essere eseguito preferibilmente da due persone. Va tenuto conto di almeno mezza giornata per completare la procedura di montaggio.

Selezione della posizione - La serra deve essere montata, posizionata e fissata su una superficie piana.

Scegliere una posizione esposta al sole che non si trovi sotto un albero.

Si raccomanda di ancorare saldamente la serra al terreno.

Si declina ogni responsabilità per eventuali danni arrecati a persone o cose a causa della serra trasportata dal vento.

Estrarre tutte le componenti dall'imballaggio.

Ordinare le parti e verificarle con l'elenco contenuto nella confezione.

Durante il montaggio le parti devono essere tenute a portata di mano.

Tenere tutte le parti piccole (come viti ecc.) in una vaschetta perché non vadano perse.

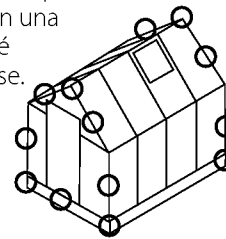

⇒ Durante il montaggio

Si invita ad eseguire le fasi di montaggio nell'ordine in cui sono descritte nelle istruzioni.

Si può usare spray lubrificante ai siliconi per far scivolare i profili sui connettori. Non usare lo spray sui pannelli di policarbonato.

Usare il martello di gomma se necessario.



Passo 1: Assicurare che la base sia quadrata misurandone le diagonali e portarla a livello usando una livella a bolla d'aria.

Passo 4: Le parti A994, A995 sono situate sul fondo della serra. Il loro fissaggio determina il lato anteriore della serra.

Passi 7, 10: Il foro ovale delle traverse A256 deve sempre essere montato alla base della serra.

Montaggio della porta (Passi 8, 43 - 49)

La porta può essere montata a scelta con il battente a sinistra o a destra. In queste istruzioni si fa riferimento al battente sul lato destro della porta.

Passo 8: determina la direzione del battente della porta 987 dove si trovano i cardini della porta.

Passi 43 - 49: Il montaggio della porta avviene secondo questa decisione.

Passo 28: Decidere la posizione della finestra prima del montaggio. La finestra può essere installata in una delle posizioni alternative indicate.

Passo 42: Nel caso in cui la finestra non si chiude correttamente, allentare le viti, regolare il profilo e stringere la vite.

Passo 51: Fissare fermamente la serra in una posizione finale piana a livella subito dopo aver completato il montaggio.

Serrare tutte le viti al momento di compilare il montaggio.

- Le viti 411 ed i dadi 412 sono usati in tutto il processo di montaggio.
- Le viti 411 devono essere inserite dall'esterno ed i dadi 412 dall'interno della serra.
- Non serrare le viti ed i dadi (411 e 412) più di 2-3 giri. Non serrare fino a montaggio completato dei pannelli, se non stabilito diversamente.
- Tuttavia, in alcuni passi, alcune viti devono essere serrate temporaneamente per prevenire che un profilo cada fino a che questo non sia collegato saldamente nei prossimi passi.



Viktigt

Läs noga igenom dessa instruktioner innan ni börjar montera växthuset. Förvara dessa instruktioner på en säker plats för framtida referenser.

⇒ Kundservice

För rådgivning av montering eller byte av delar – vänligen kontakta oss via e-mail eller telefon (nummer finns på förstasidan).

Ytterligare information finns på producentens hemsida: www.palramapplications.com

⇒ Säkerhetsföreskrifter

- Följ monteringsanvisningarna i den ordning som anvisas i instruktionerna, hoppa inte över något steg.
- Vi rekommenderar att handskar, skor och skyddsglasögon alltid används då man arbetar med metallprofiler.
- Vid användning av stege, redskap och bormaskin, följ tillverkarens säkerhetsråd.
- Var noga med att inte komma i kontakt med elkablar då metallprofiler hanteras.
- Undvik att montera växthuset i dåligt, blåsigtt väder eller regn.
- Ta väl hand om all plastpåsar och se till att de är utom räckhåll för barn.
- Låt inte barn vistas på monteringsplatsen och håll omgivningen snygg.
- Luta eller tryck inte på växthuset under montering.
- Välj omsorgsfullt platsen för växthuset så att det inte påfrestras av kraftig vind eller extra snö.
- Försök inte att sätta ihop denna produkt om du är trött, har tagit droger, druckit alkohol eller om du brukar ha yrselattacker.
- Heta föremål som en nyligen använd grill, blåslampa eller dylikt får inte förvaras i växthuset. Försäkra att det inte finns några dolda rör eller kablar i marken innan du slår ner metallfästena för att förankra växthuset.
- Denna produkt är endast avsedd för att användas som växthus.

⇒ Underhåll & skötsel

När växthuset behöver rengöras skall du använda ett mildt rengöringsmedel och skölja rikligt med kallt och rent vatten.

Använd inte aceton, slipande rengöringsmedel eller andra specialmedel för att rengöra panelerna. Vi rekommenderar att man tidvis kontrollerar takpanelernas fäste (även plastfästen 329 och profiler 981) och försäkrar deras rätta position.

⇒ Verktyg & redskap

- Måttband
- Handskar
- Silikonspray
- Krysskruvmejsel
- Stege
- Drill bit
- Hammare (stor)

- Sax
- Skiftnyckel
- T001 verktyg (inkl. förpackningen)



⇒ Före montering

Detta är ett monteringsarbete som bäst utförs av min. två personer. Reservera åtminstone en halv dag för monteringsprocessen. Före monteringen bör grunden vara välgjord på den valda platsen.

Försäkra att grundens mått passar ihop med växthusets sockelmått. Vid val av växthusets positionering bör grunden vara rak. Välj en solig plats fri från skuggande träd och grenar. Is och snö från träd, grenar eller byggnader samt vindiga platser bör undvikas. Växthuset bör fästas stadigt i grunden med tillhörande metallsockel.

Metallsockeln har färdiga fästpositioner. Börja med att tömma förpackningen och försäkra att

alla delar finns – kontrollera innehållsförteckningen att delarna är korrekt märkta samt att de finns i rätt mängd.

Håll alla delar nära dig vid monteringen. Förvara alla smådelar (skruvar, muttrar o.s.v.) i en skål så att de inte tappas bort. Alla delar är märkta med nummer och bör användas.

I några profiler kan fästen bli oanvända p.g.a produktionstekniska grunder.

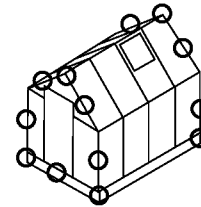

⇒ Under monteringen

Utför montering i den ordning som anges i instruktionerna.

Du kan använda silikonsprayen som hjälp för att glida profilerna på kopplingarna.

Spraya inte polykarbonatpanelerna.

Använd gummihammare om det behövs.



Steg 1: Försäkra att underlaget är plant, och vågrätt samt diagonalt.

Steg 4: Delarna A994 och A995 tillhör växthusets bakre vägg. Vid montering av dessa delar bestämmer du sida för dörren, se punkt 8.

Steg 7, 10: Sidostödets A256 ovala hål bör monteras ner.

Montering av dörr (Steg 8, 43-49)

Dörrens öppningsriktning kan väljas. Denna instruktion följer höger öppningsriktning.

Steg 8: Bestäm öppningsriktningen Profil 987 är gångjärnssidan.

Steg 43-49: Dörrens montering följer vald riktning.

Steg 28: Bestäm takluckans position. Takluckan kan installeras enligt punkt 30 men bör helst inte riktas mot solen (söder – sydväst).

Steg 42: Om fönstret inte stängs ordentligt, lossa skruvarna, justera profilen och dra åt skruvarna.

Steg 51: Försäkra ett stadigt fäste av basen i underlaget när monteringen är färdig.

Dra åt alla skruvar när du slutför monteringen.

Skruv 411 och mutter 412 används genom hela monteringsprocessen.

- Skruv 411 ska monteras från utsidan och mutter 412 från växthusets insida.
- Om inte annat anges, dra inte åt skruv och mutter (411 och 412) mer än 2-3 varv. Dra inte åt dem förrän monteringen av panelerna är avslutad. Dessa två ikoner anger om du behöver dra åt skruv eller inte.
- Tillfällig åtdragning kan i vissa steg behövas för att förhindra en profil från att falla tills den är fullt ansluten i kommande steg.



Contents

Item	Inc./cm	Qty.
957	62 ¹ / ₂ / 159	2

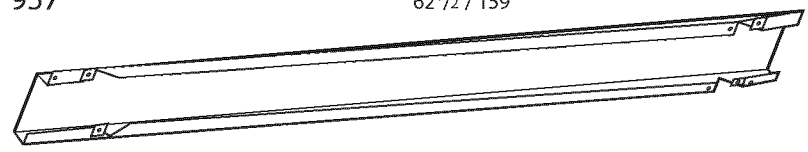

958	63 / 160	2
-----	----------	---

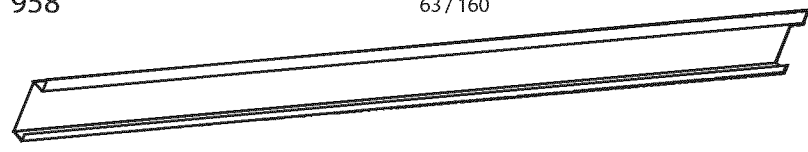

976	48 ³ / ₄ / 119	2
-----	--------------------------------------	---



977	48 ³ / ₄ / 119	1
-----	--------------------------------------	---

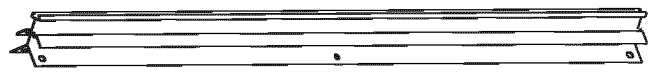

955	70 / 178	1
-----	----------	---

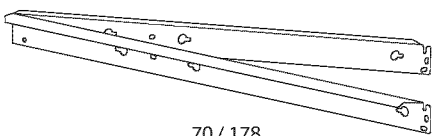

Item	Inc./cm	Qty.
994	67 / 170	1



995	67 / 170	1
-----	----------	---



987	65 / 165	1
-----	----------	---

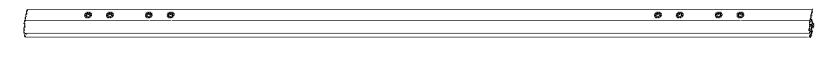

988	65 / 165	1
-----	----------	---



985	64 / 163	2
-----	----------	---

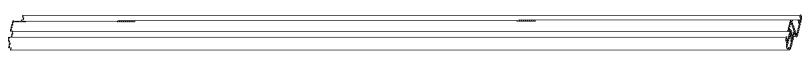

Contents

Item	Inc./cm	Qty.
256	50 ³ / ₄ / 129	4

993	46 / 117	4
-----	----------	---

996	46 / 117	8
-----	----------	---

3017	22 ³ / ₄ / 53	2
3016	64 / 163	1

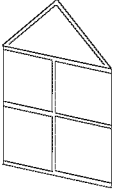
Item	Qty.
553 	1

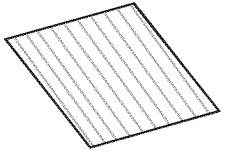
586 	2
----------------------------------------------------------------------------------------	---

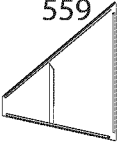
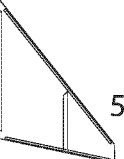
559 	2
560 	2

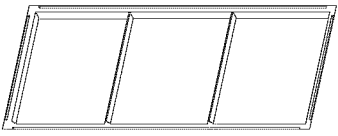
7011 	9
------------------------------------------------------------------------------------------	---

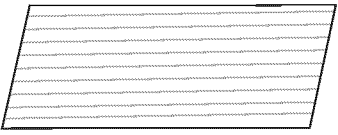
581 	3
------------------------------------------------------------------------------------------	---

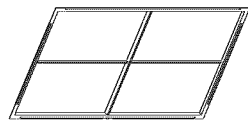
567 	2
------------------------------------------------------------------------------------------	---

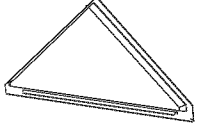
Item	Inc./cm	Qty.
570 		1

989 	24 ¹ / ₄ / 61.5	1
-----------------------------------------------------------------------------------------	---------------------------------------	---

991 	24 ¹ / ₄ / 61.5	1
-----------------------------------------------------------------------------------------	---------------------------------------	---

992 	22 ³ / ₄ / 58	2
------------------------------------------------------------------------------------------	-------------------------------------	---

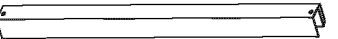
984 	21 ¹ / ₂ / 55	2
-------------------------------------------------------------------------------------------	-------------------------------------	---

981 	22 / 56	4
-------------------------------------------------------------------------------------------	---------	---

Item	Inc./cm	Qty.
286 	24 / 61	2

999 	22 / 56	5
-----------------------------------------------------------------------------------------	---------	---

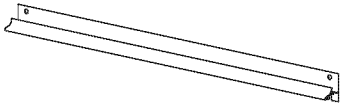

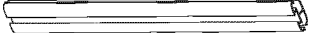









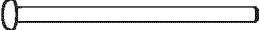
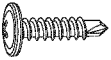

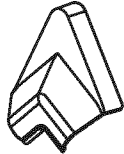
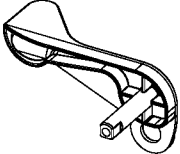

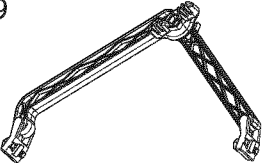

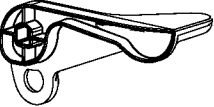
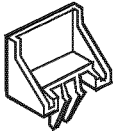
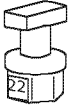
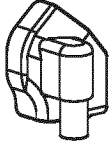
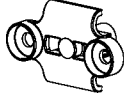
986 	24 ³ / ₄ / 63	1
-----------------------------------------------------------------------------------------	-------------------------------------	---

983 	18 ¹ / ₂ / 47	1
------------------------------------------------------------------------------------------	-------------------------------------	---

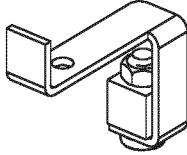
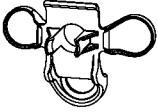
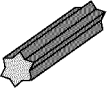
990 	22 / 56	1
-------------------------------------------------------------------------------------------	---------	---

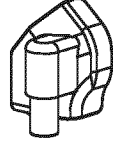
956 		1
-------------------------------------------------------------------------------------------	--	---

Contents

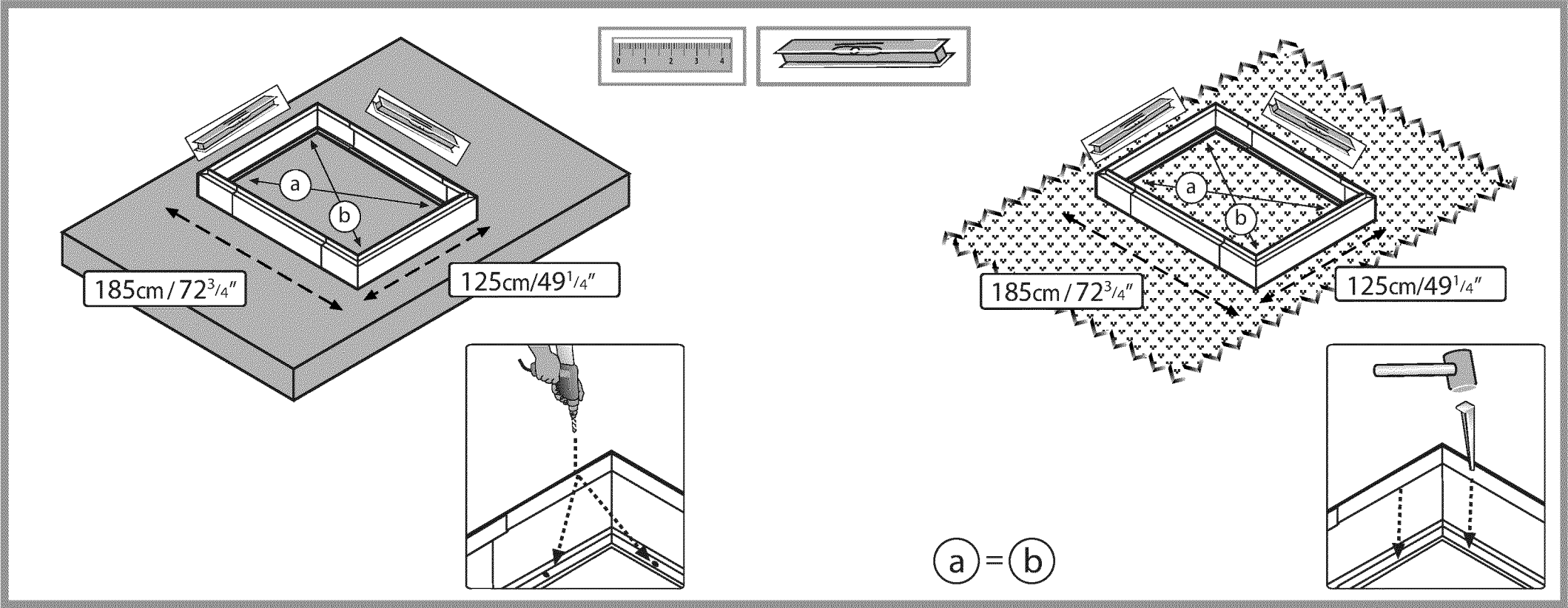
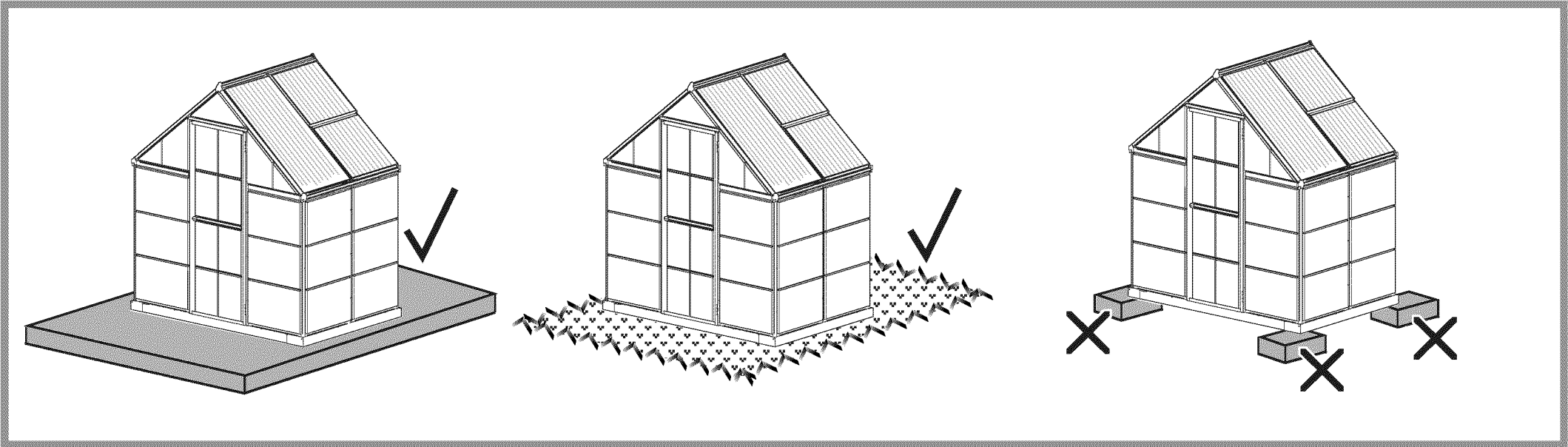

Item	Qty.	Item	Qty.	Item	Qty.	Item	Qty.	Item	Qty.
447	9	411	94	463	2				
	spare 1		spare 4						
4008	9	412	94	462	2	343	2	7083	1
	spare 1		spare 4						
4043	3	99	1	464	4	329	2	7084	1
	spare 1								
328	19	22	2	465	9	344L	2	7085	1
	spare 1			spare 1					
M96	4	288	2	422	9	4037	1	7086	1
					spare 1				
7009 (PVC)	3	959	1			344R	2	7088	1
	spare 1								M4 x 50mm
				T001	1			423	1
						318 PVC	8		M4
							spare 1		

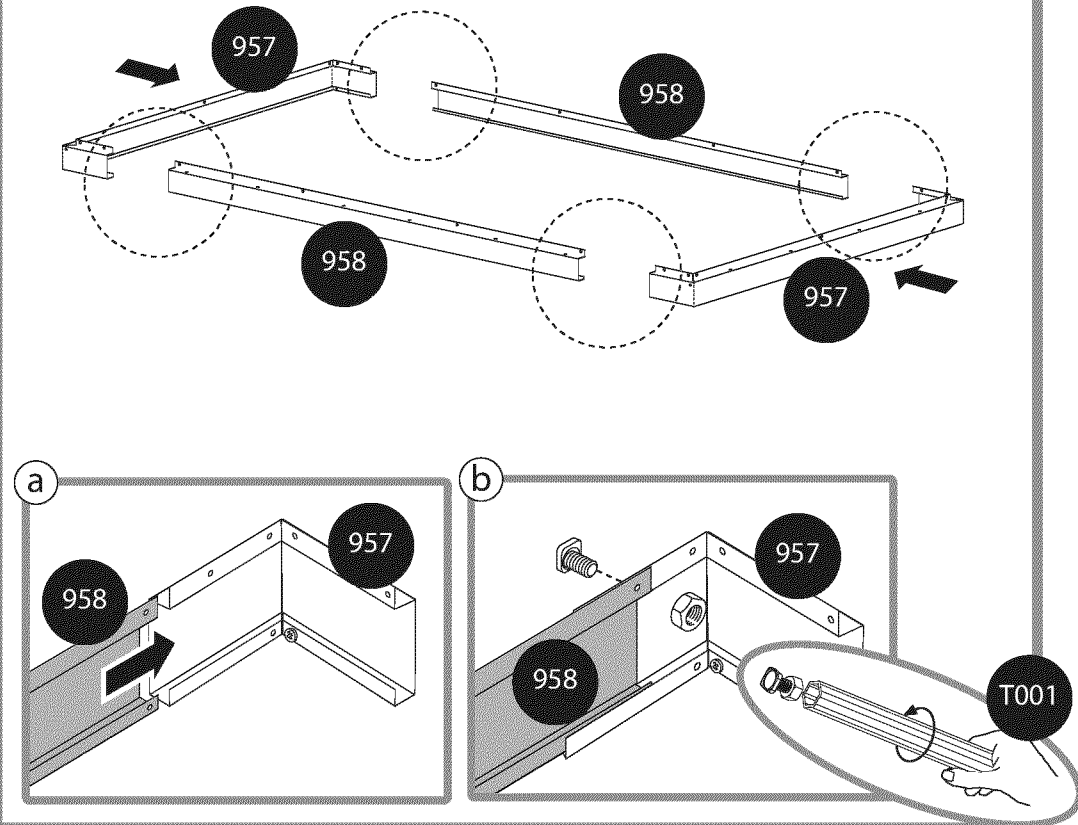
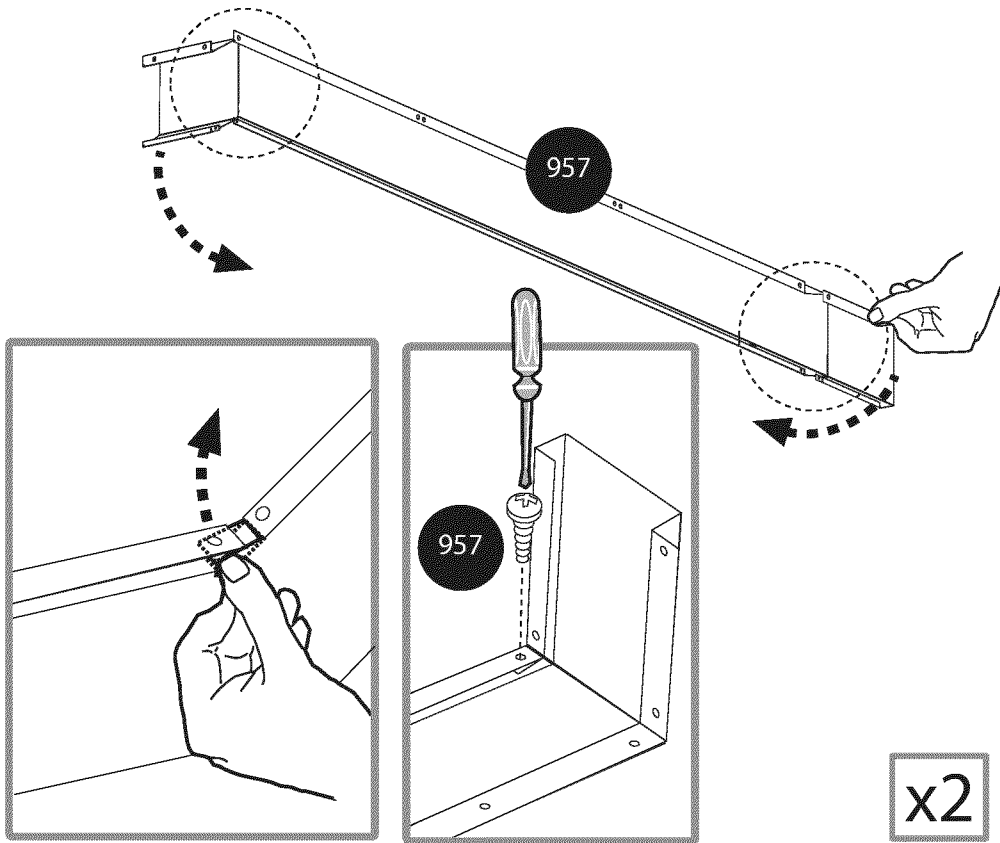
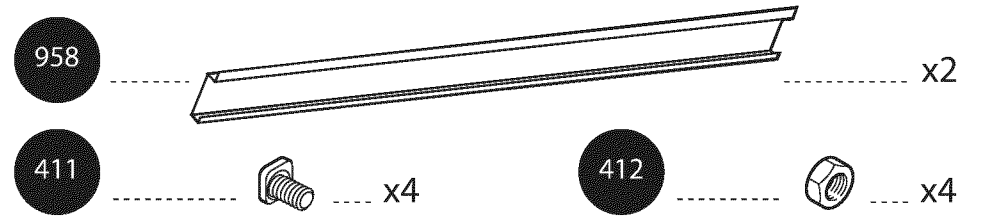
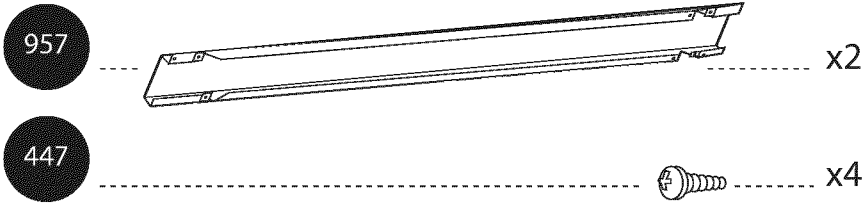
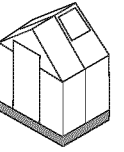

1

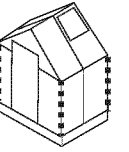

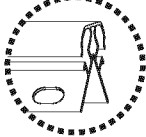

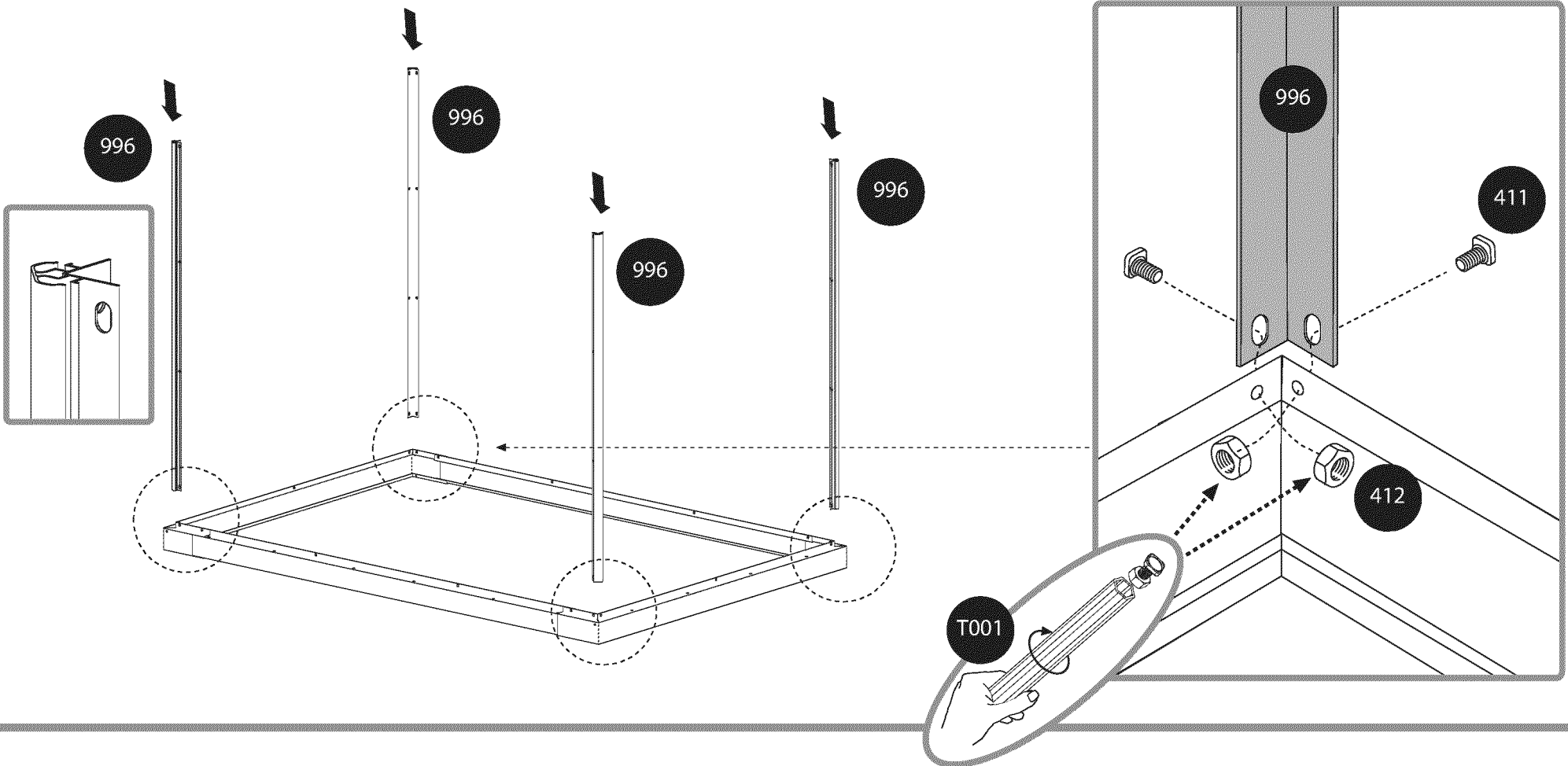

- 996   x4
- 412  x8
- 411  x8

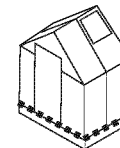

3



412  x6

411  x6

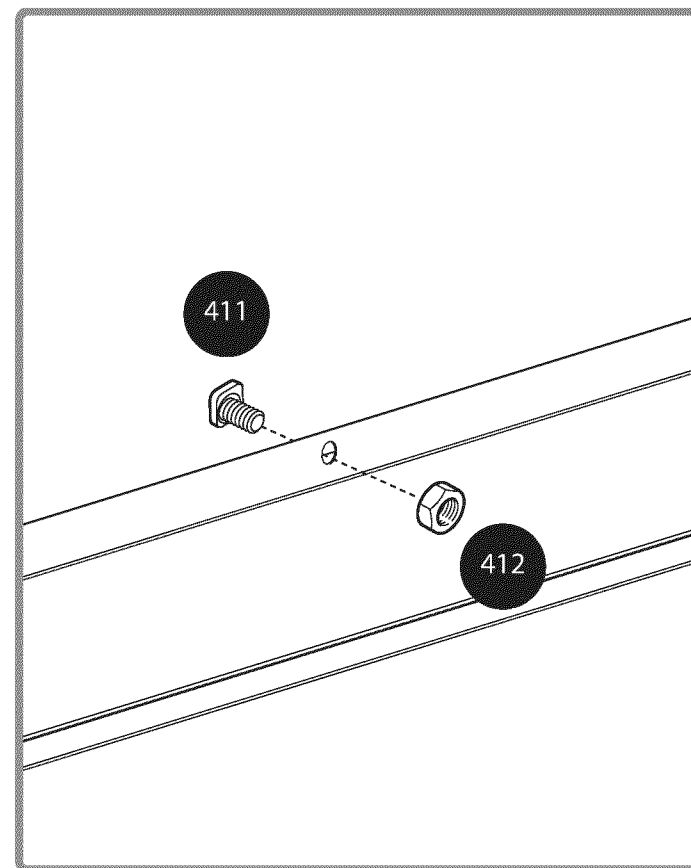
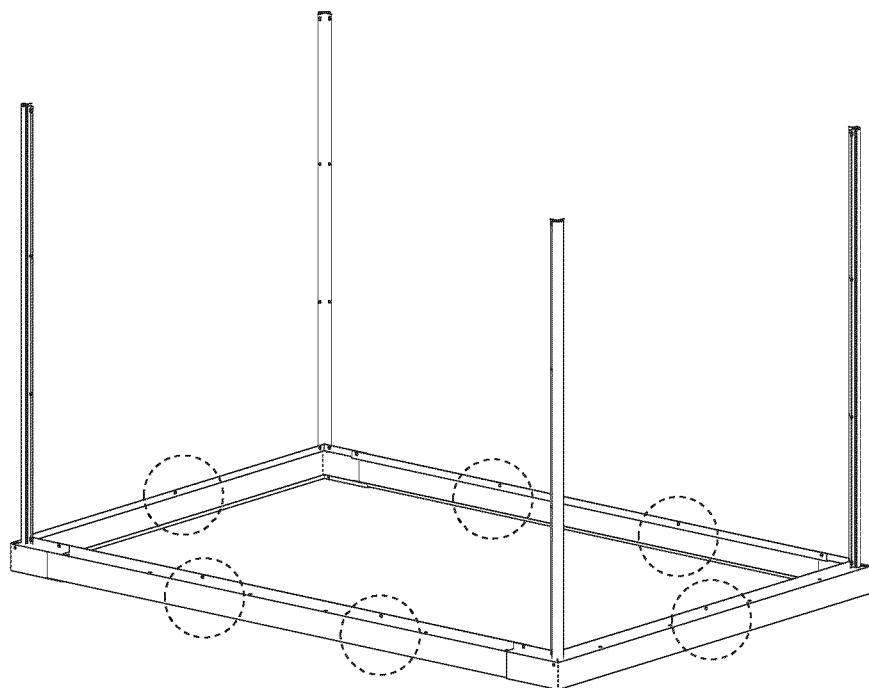

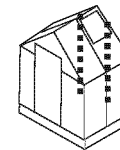

994

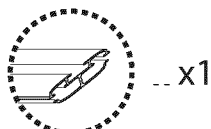

x1

995



x1

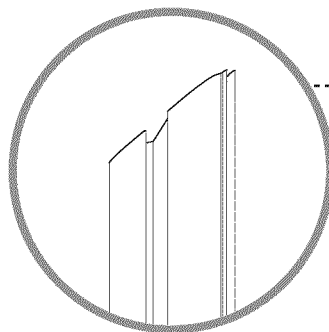

995

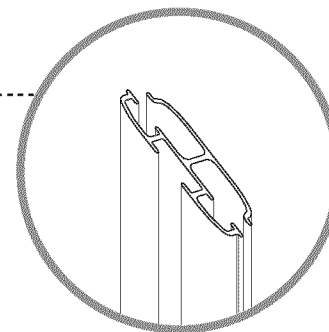

994

a

a

EN Door
GR Tür
FR Porte
SP Puerta

a

994

995

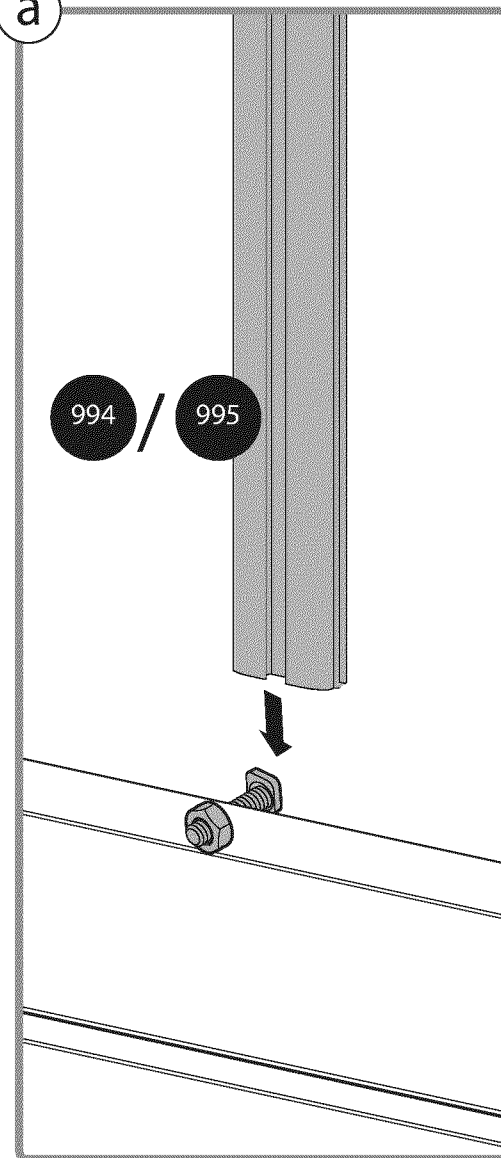

5

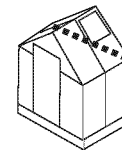

955



956

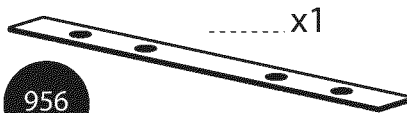

412



x6

411



x6

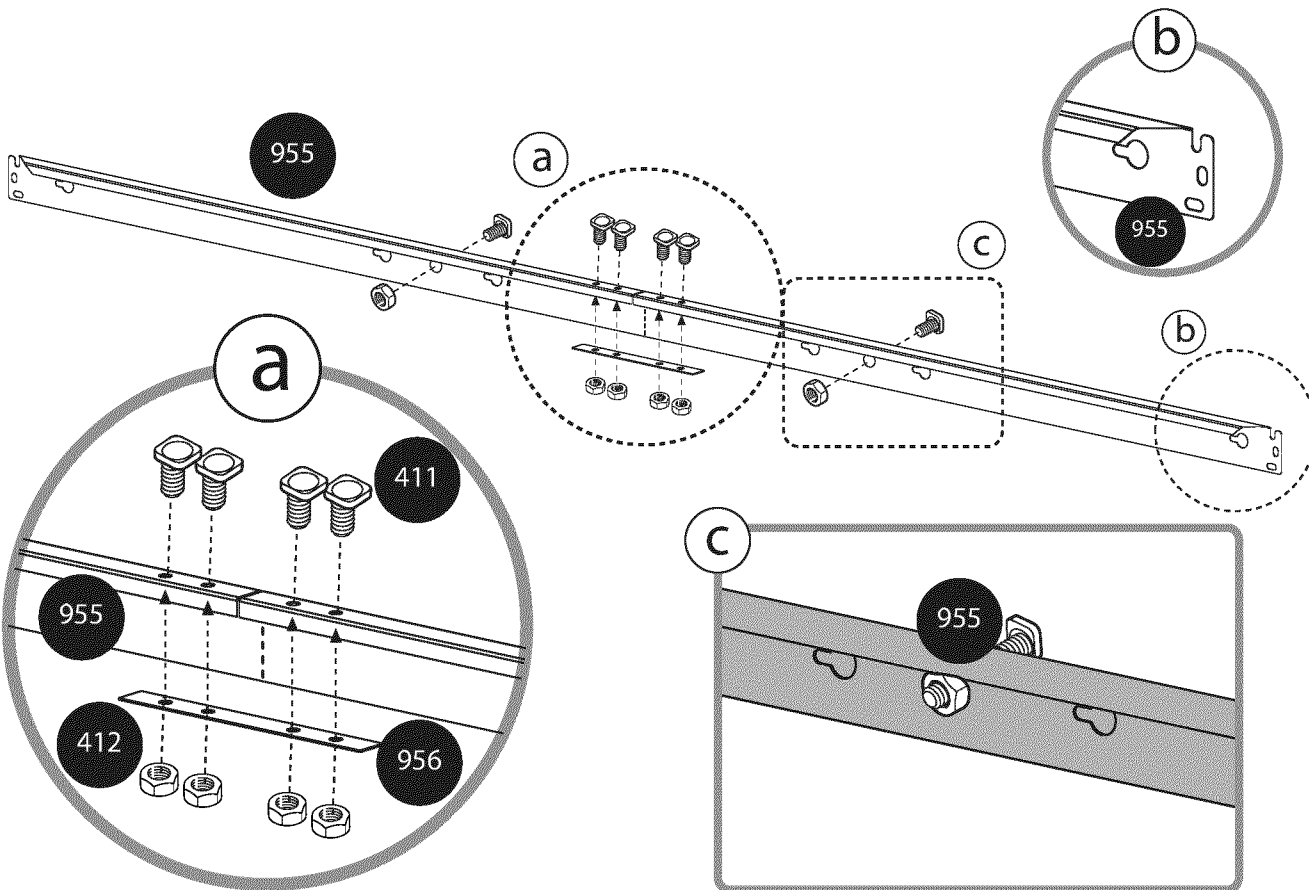
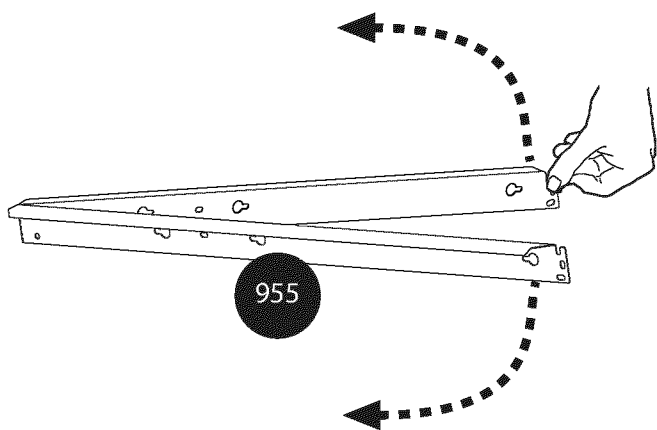

6

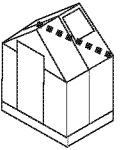

955

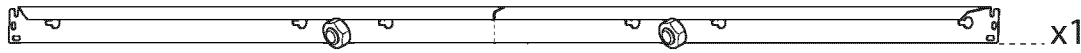

x1

411



x2

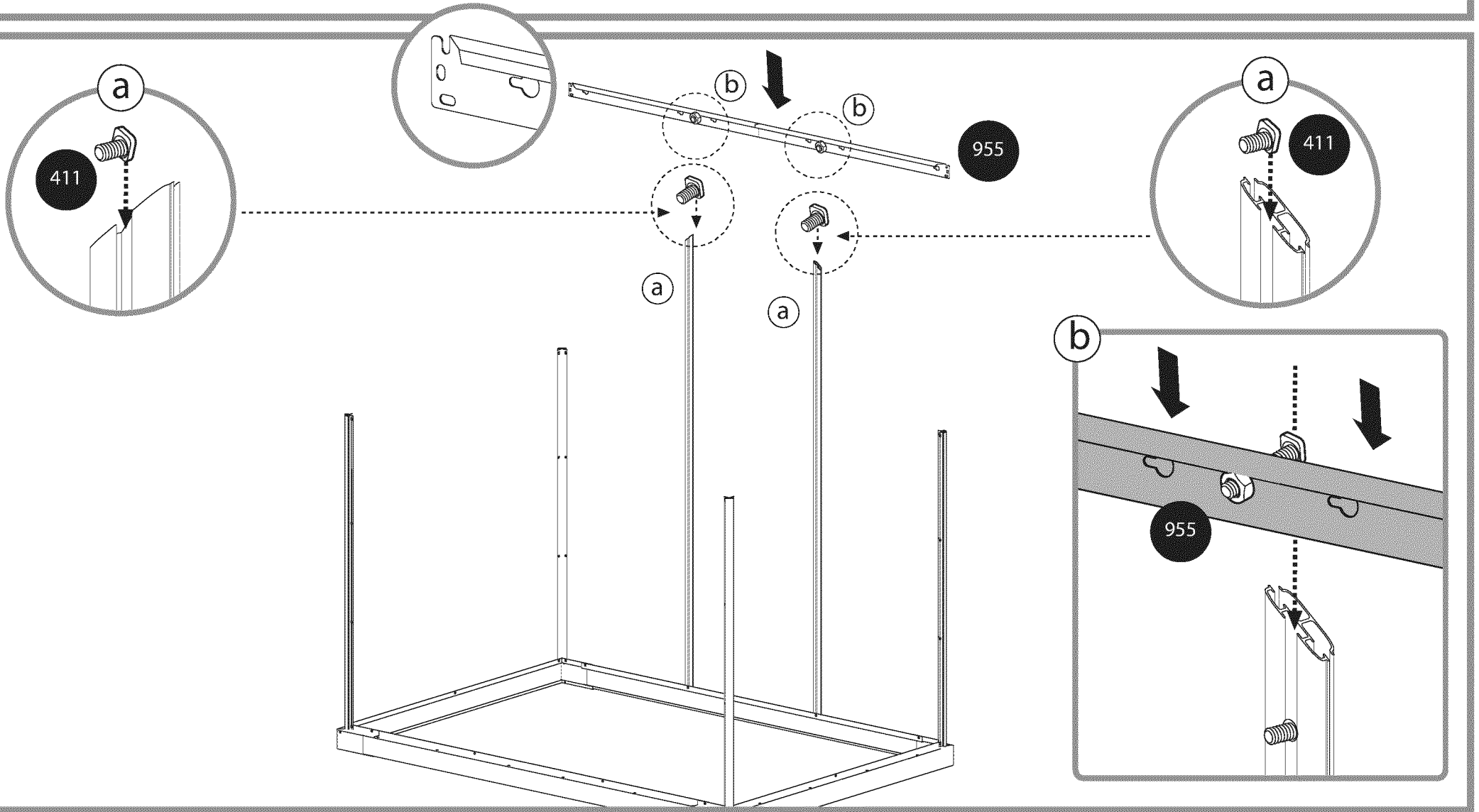

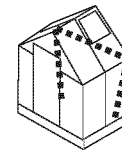

256

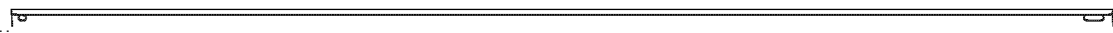

x2

412



x4

411



x2

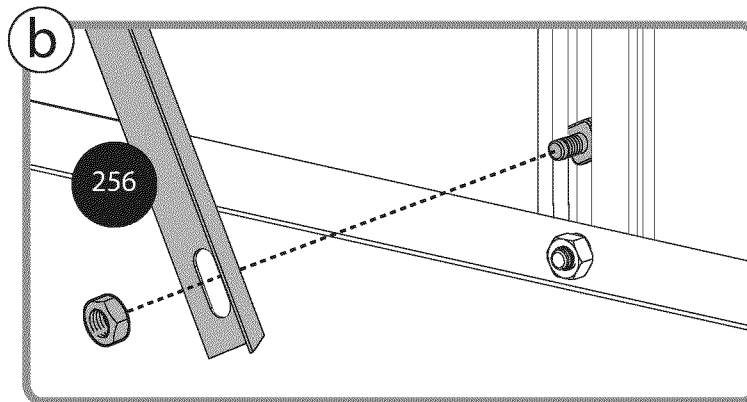
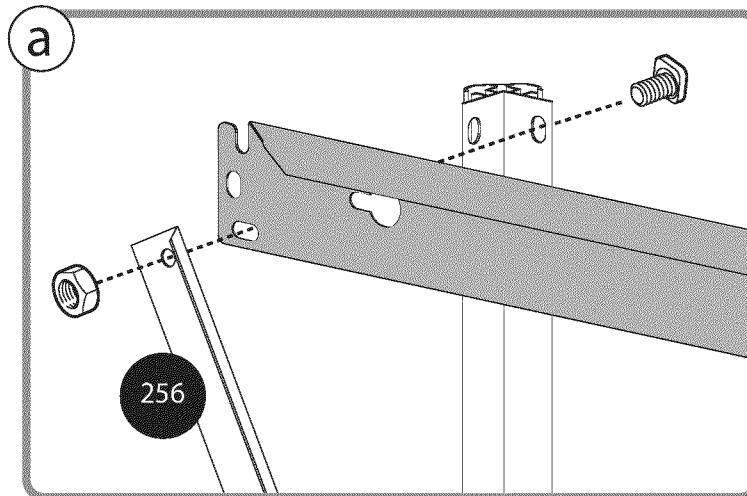
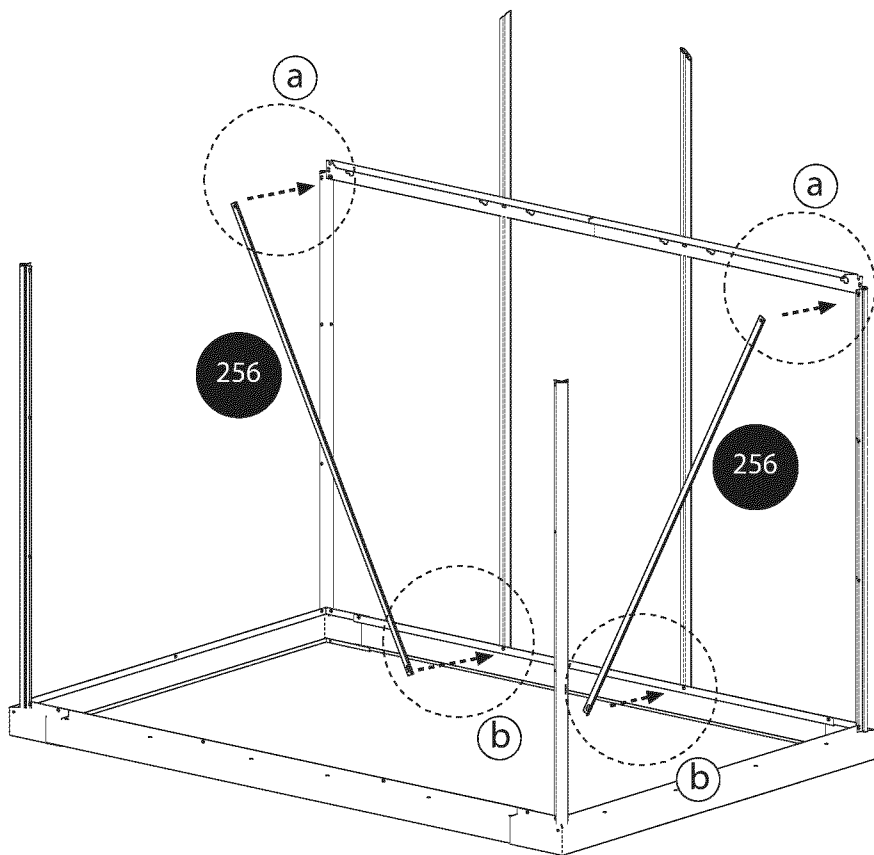

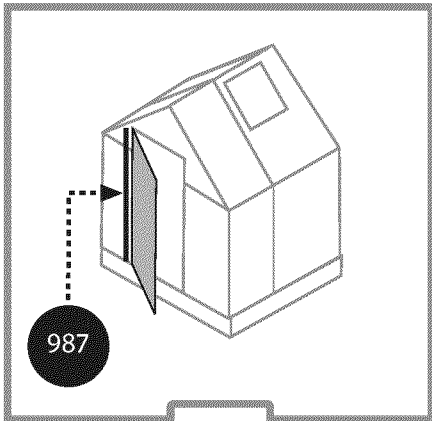
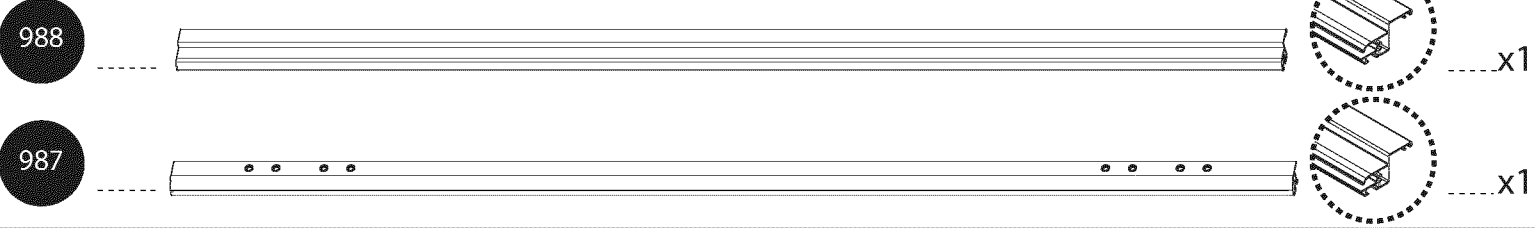
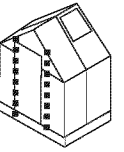

or

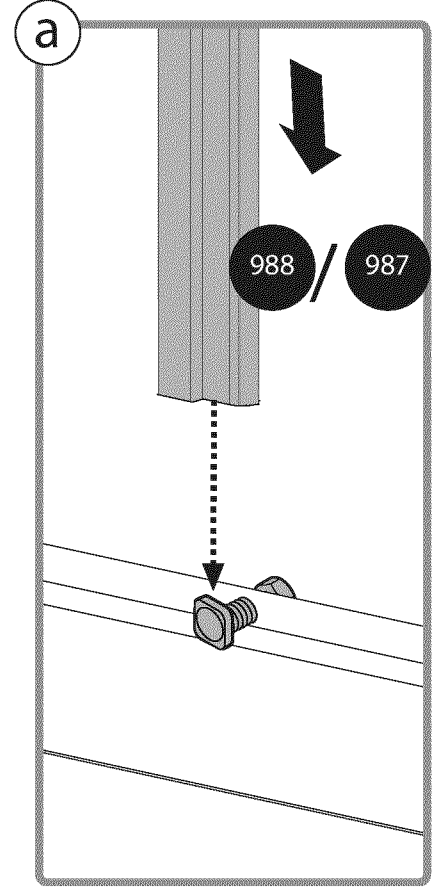
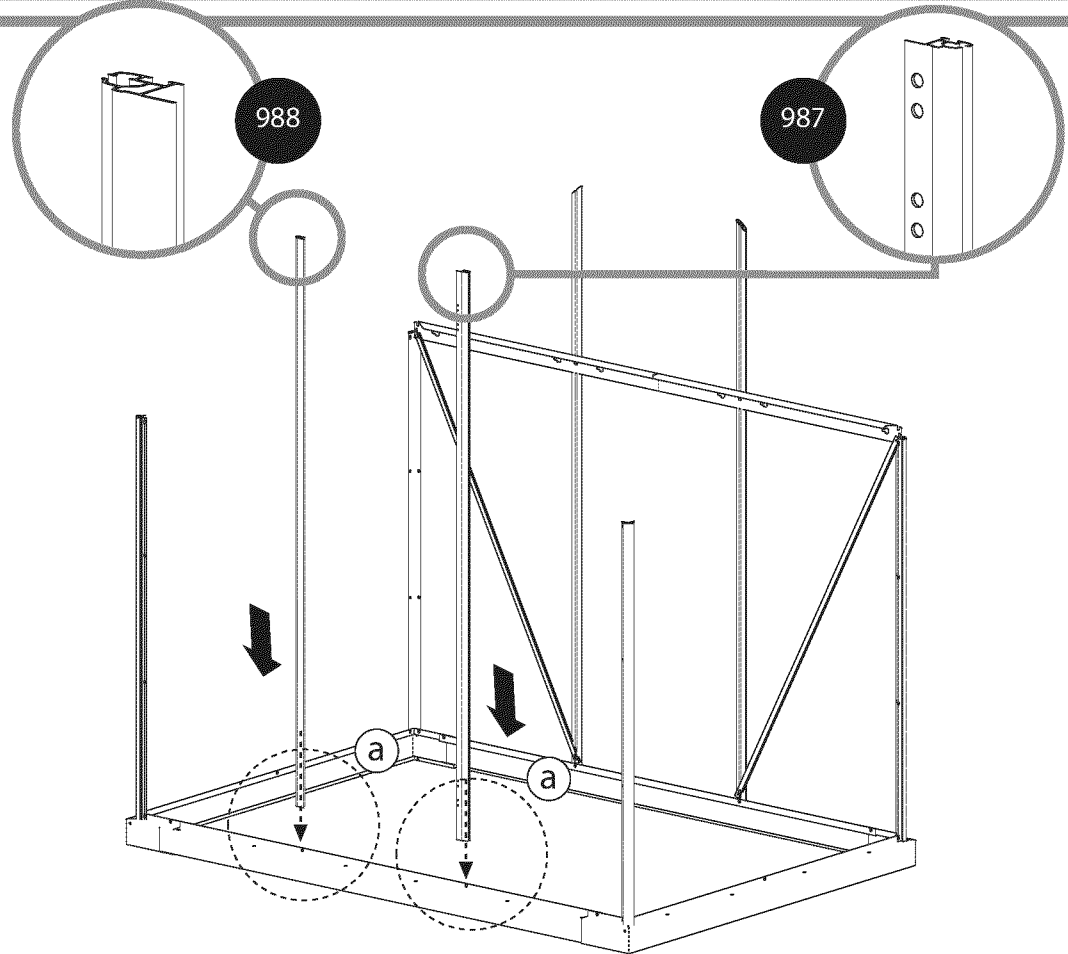
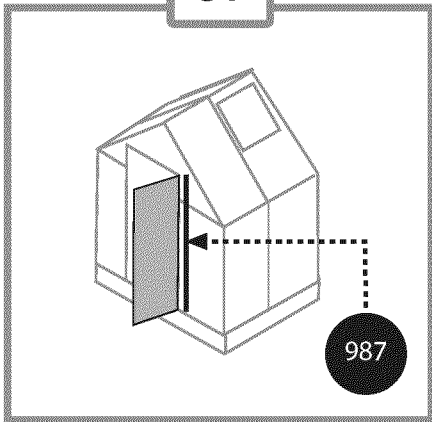

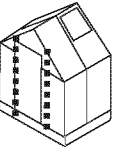

411  x2

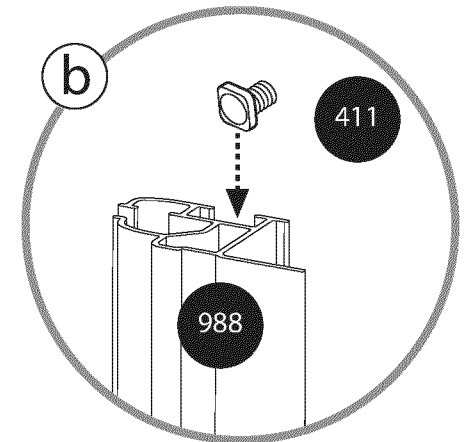
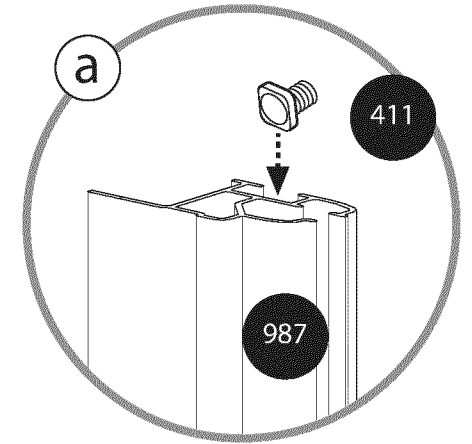
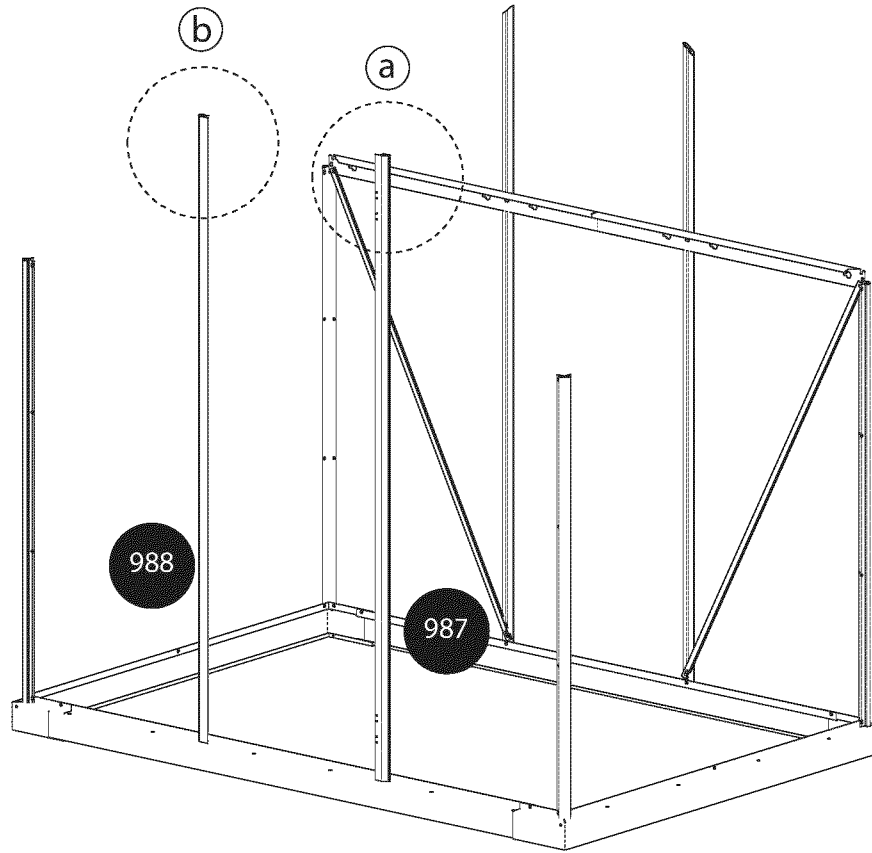



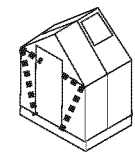

412 

411 

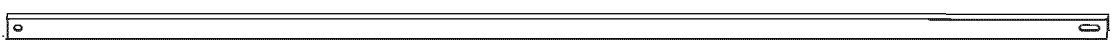

256  x2

412  x8

286  x2

411  x6

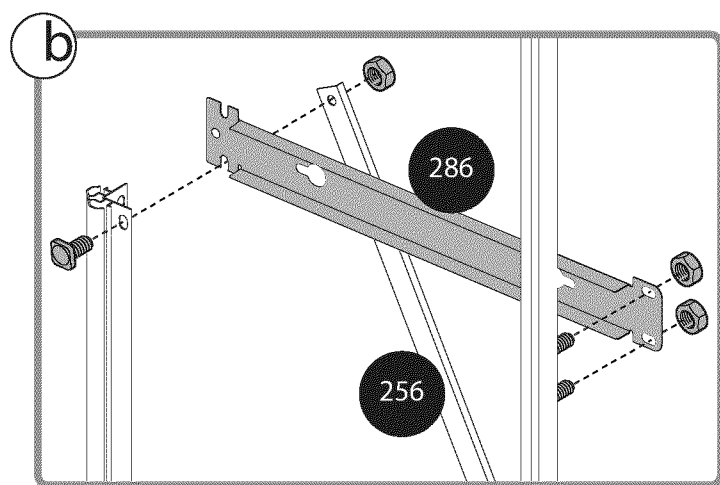

b

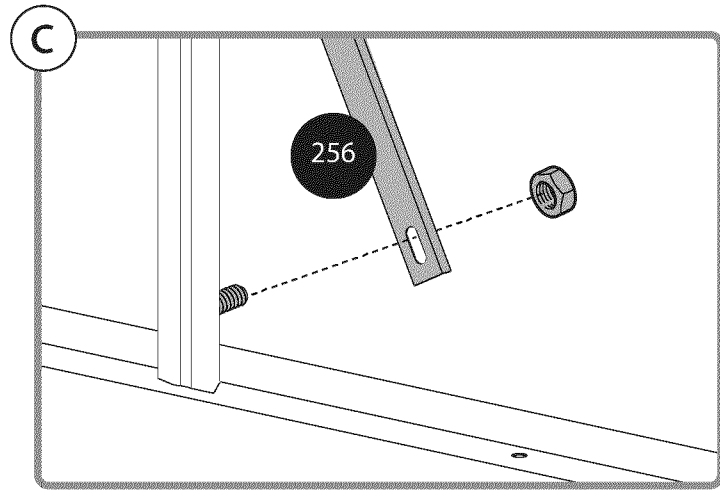

c

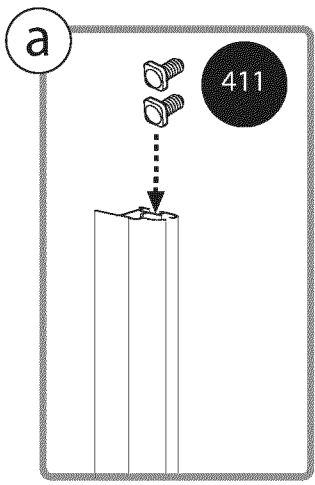
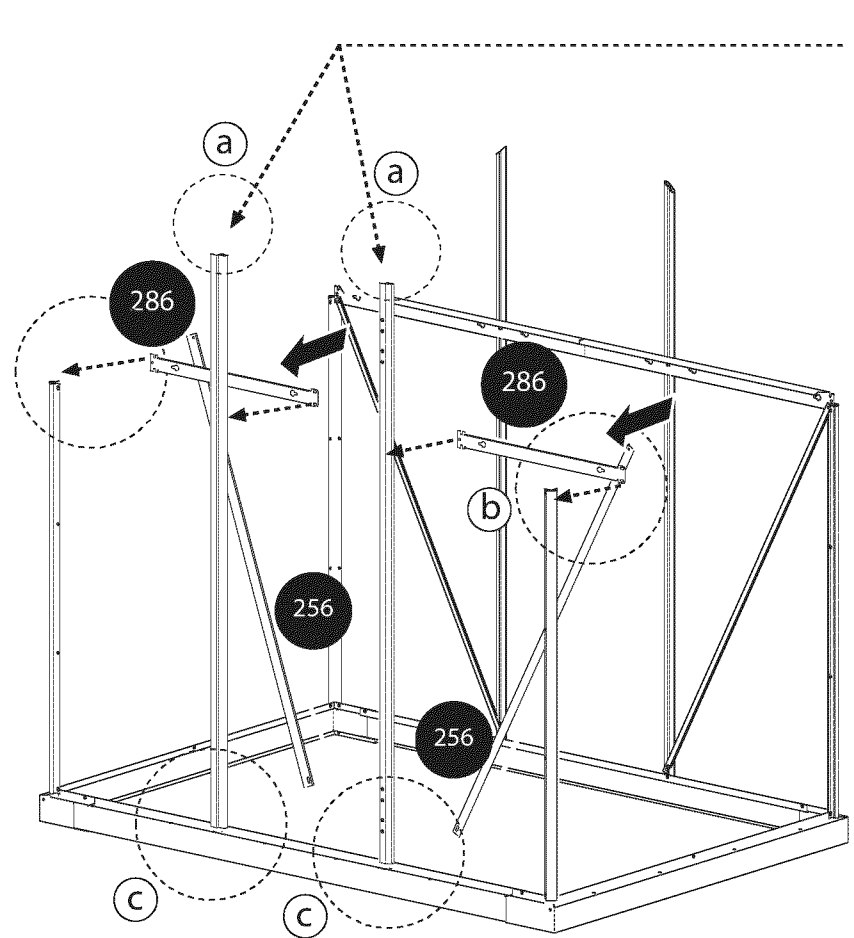

a

411

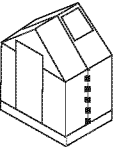

993

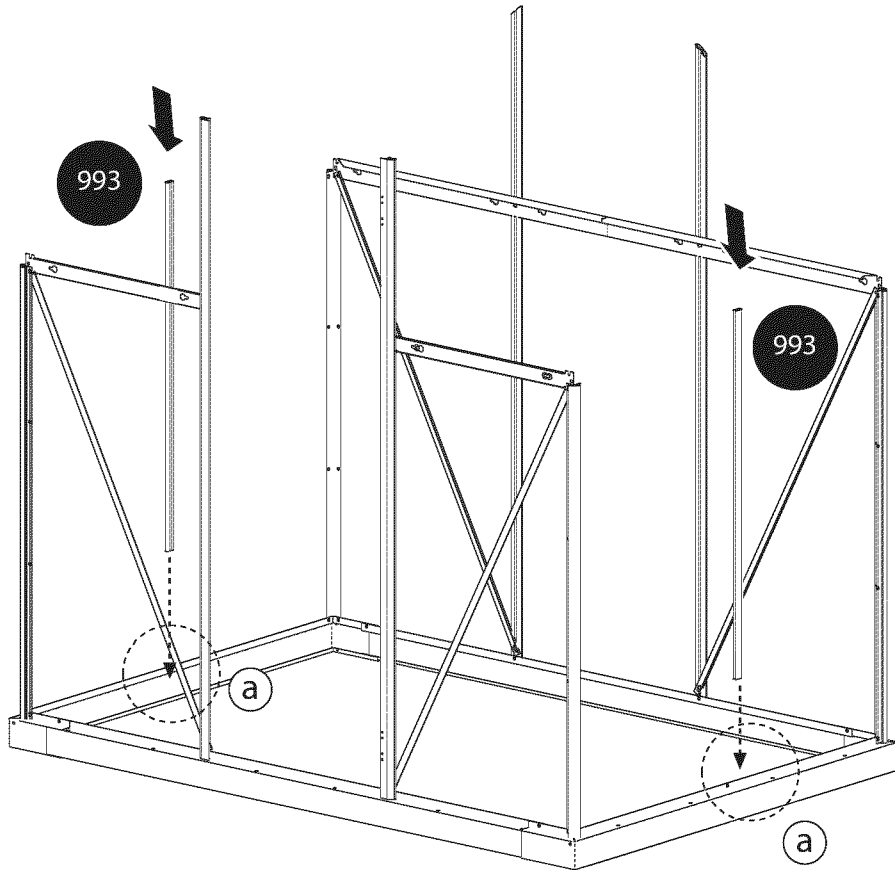
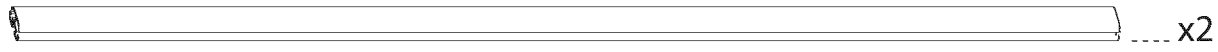
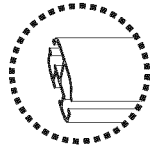

a

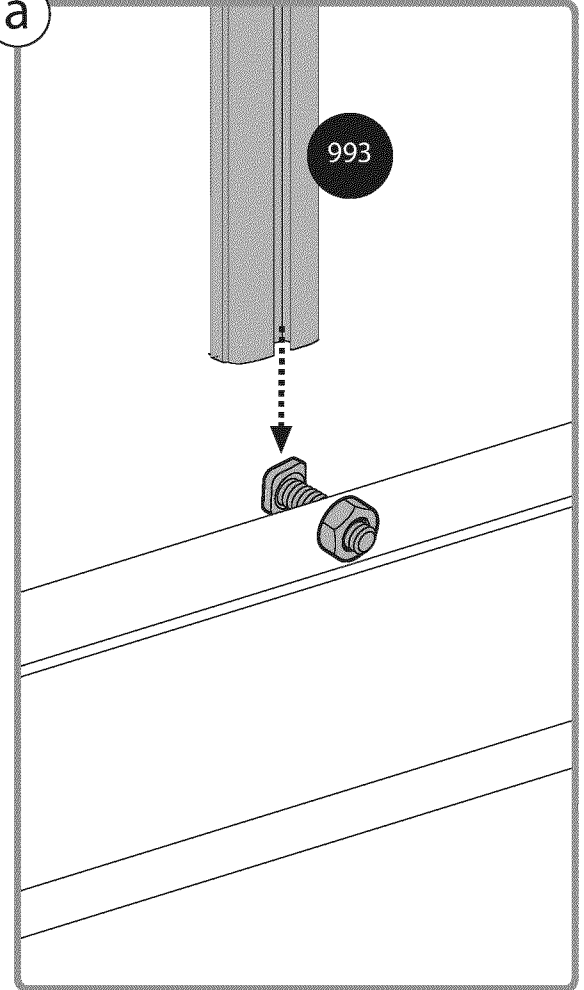

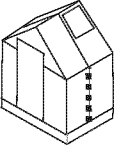

411



x4

412



x4

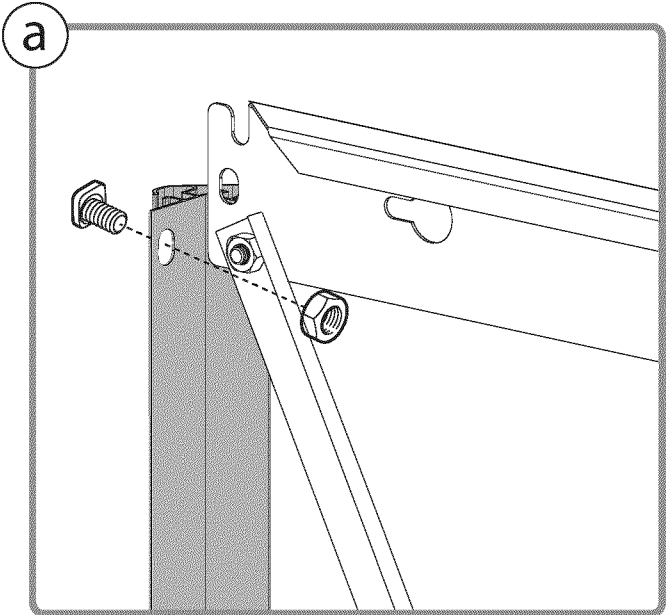
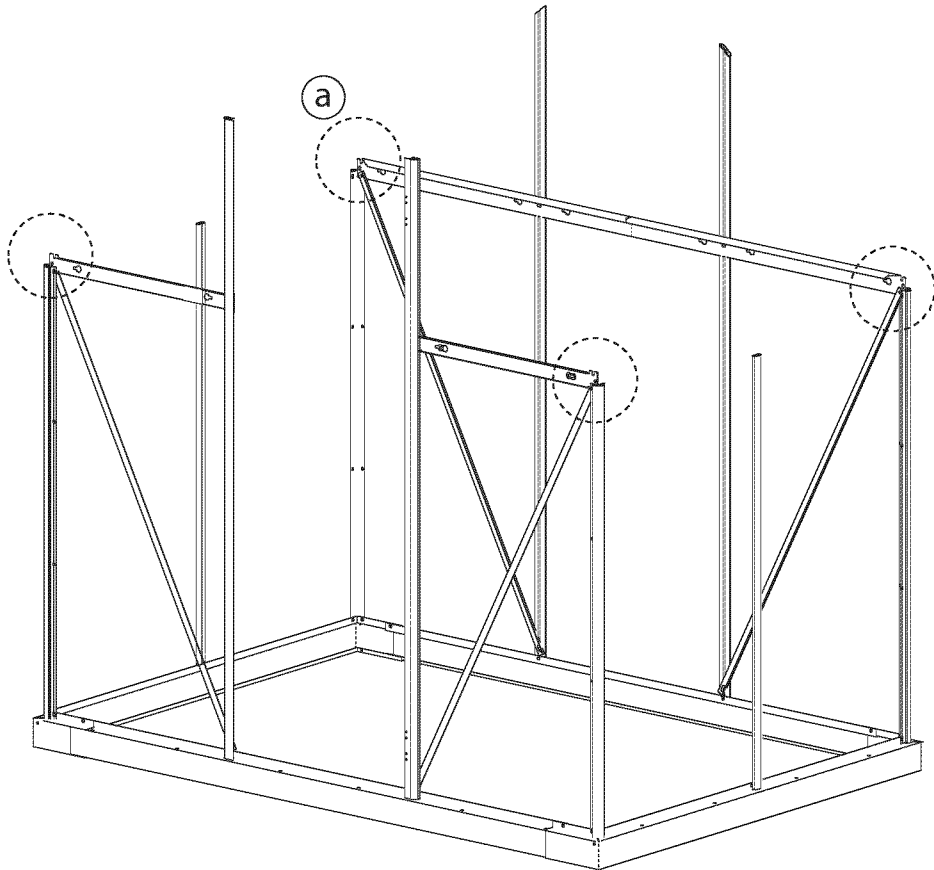

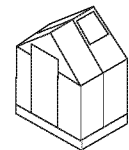

7011

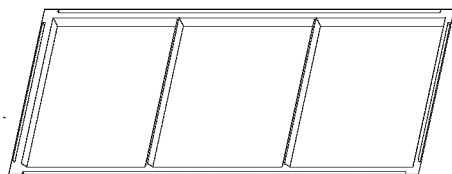

x9

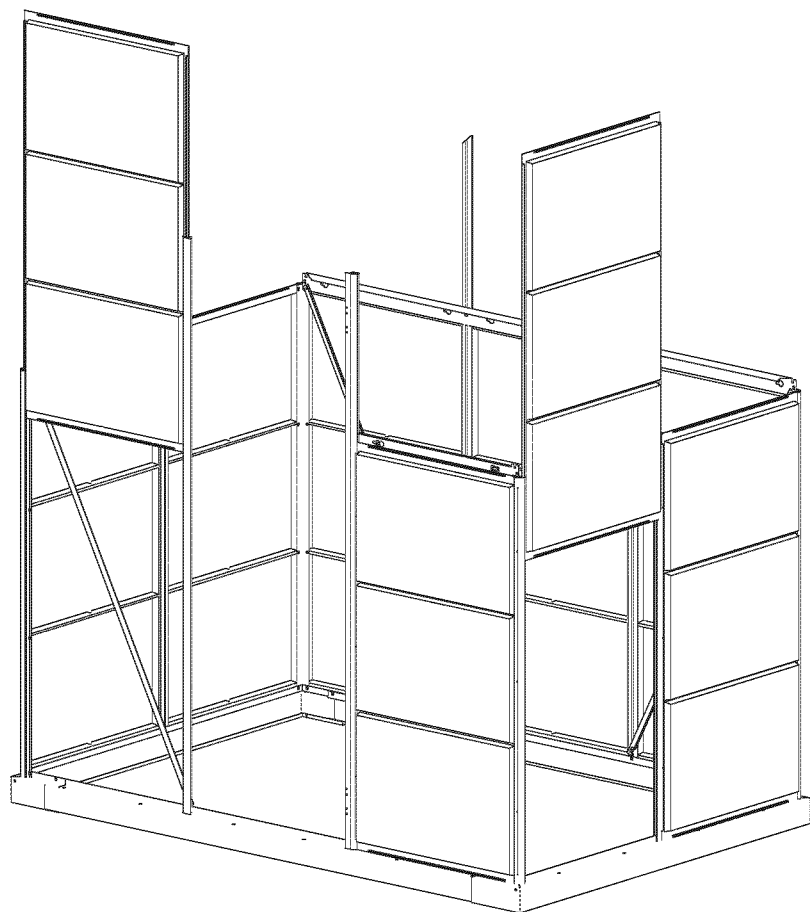

a

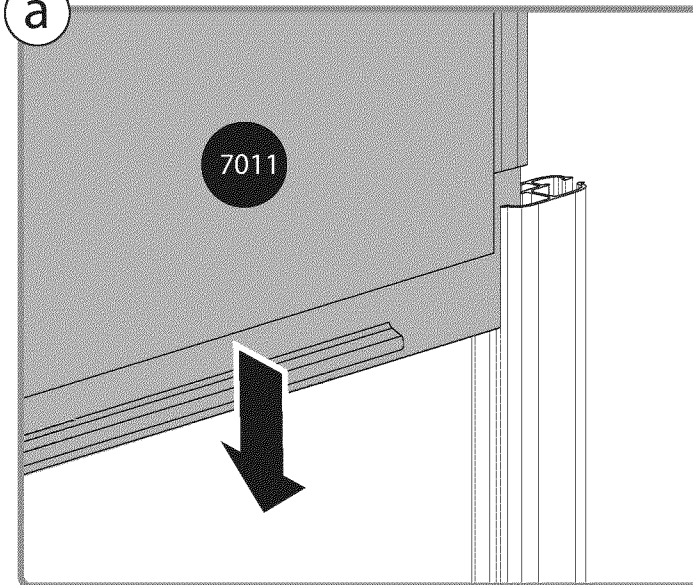

b

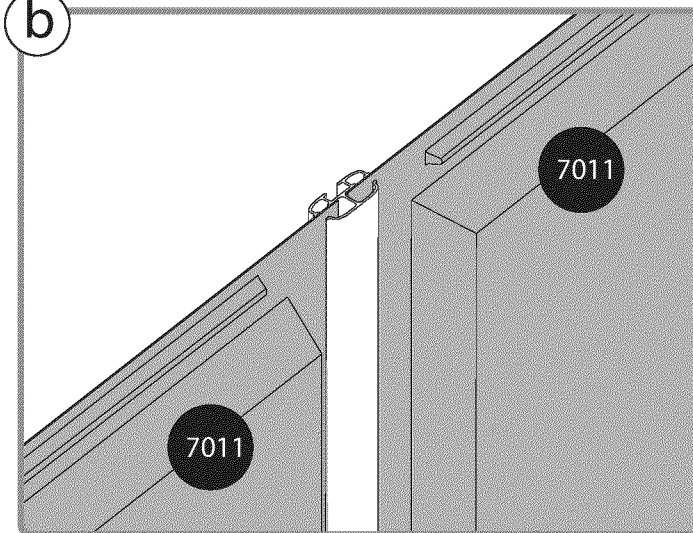

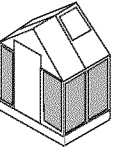

318
PVC

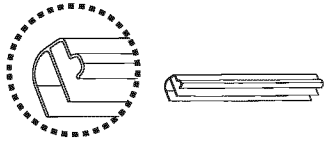

x4

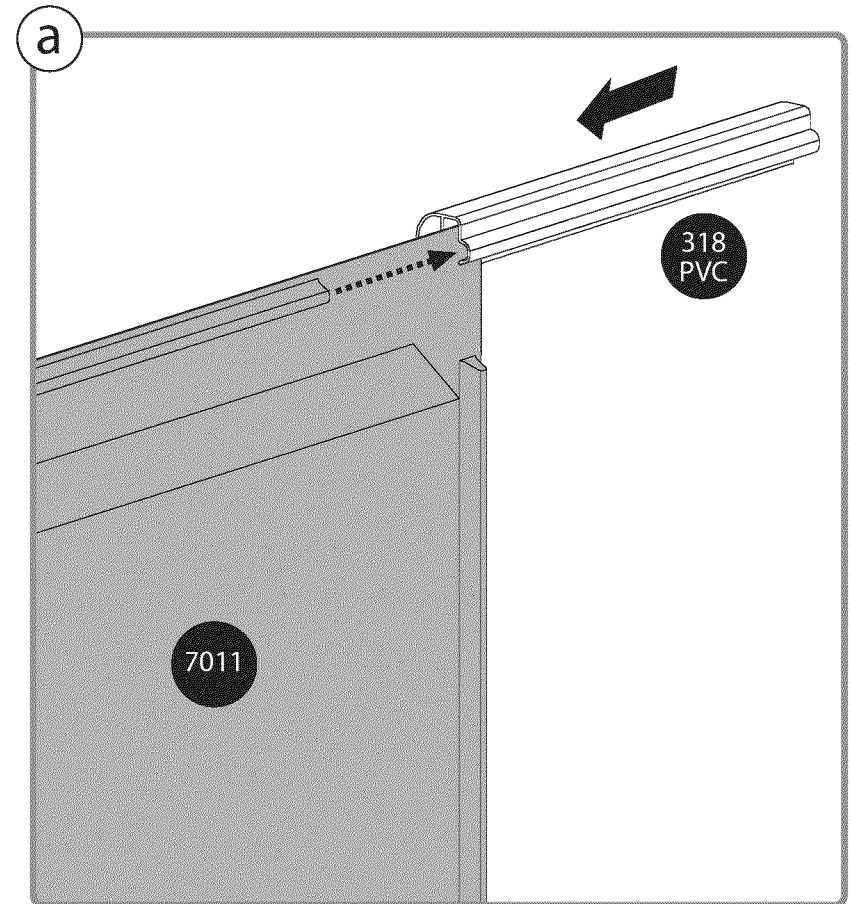
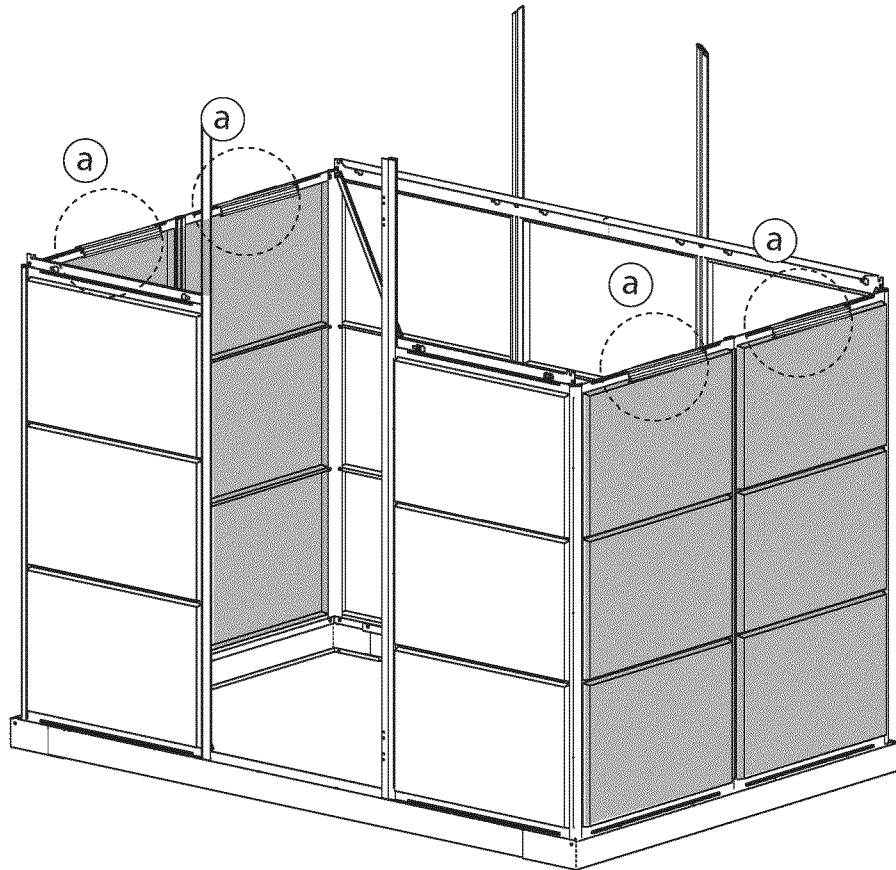

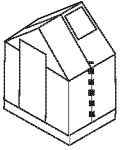

412  x2

411  x2

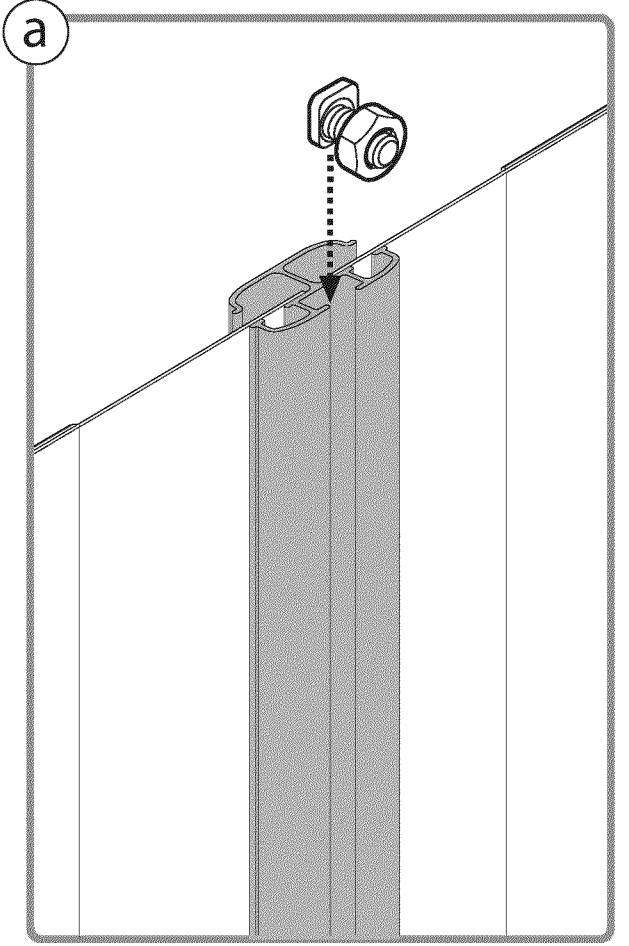
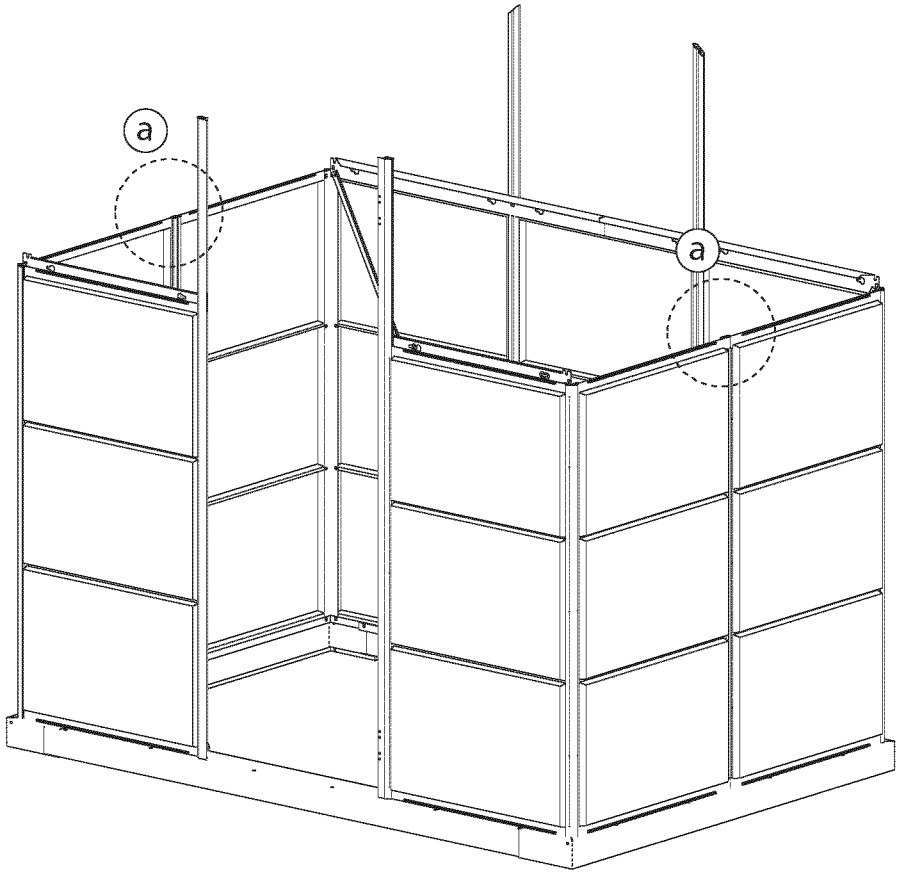

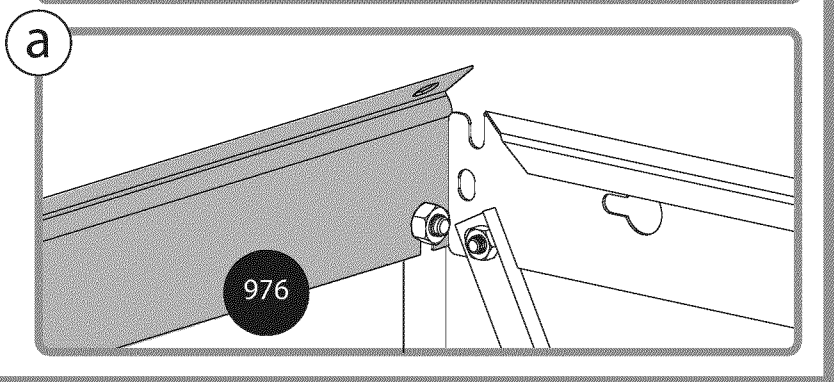
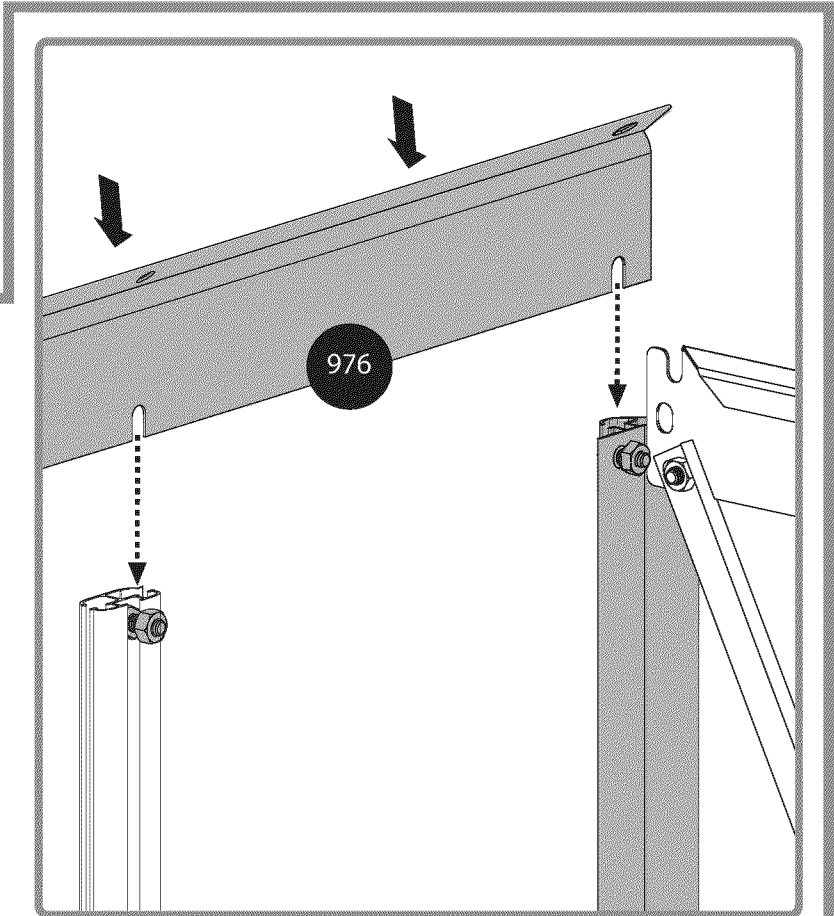
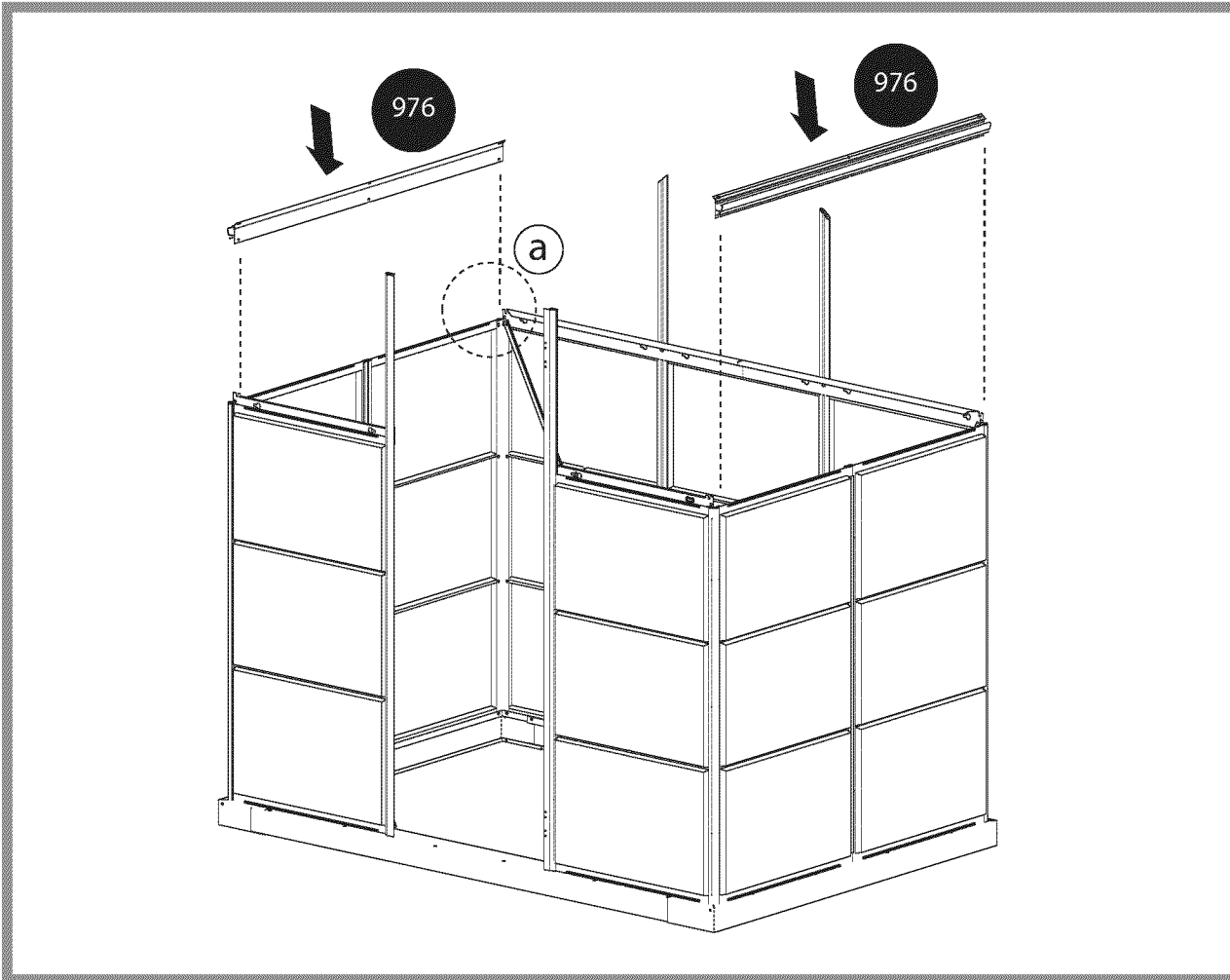
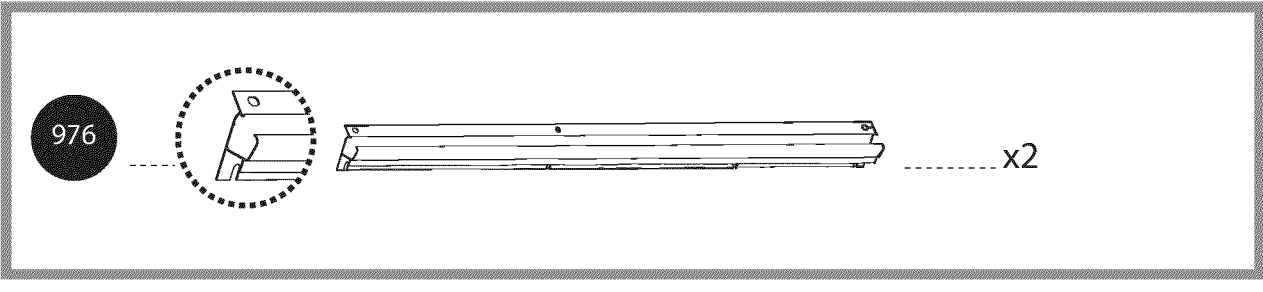
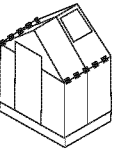

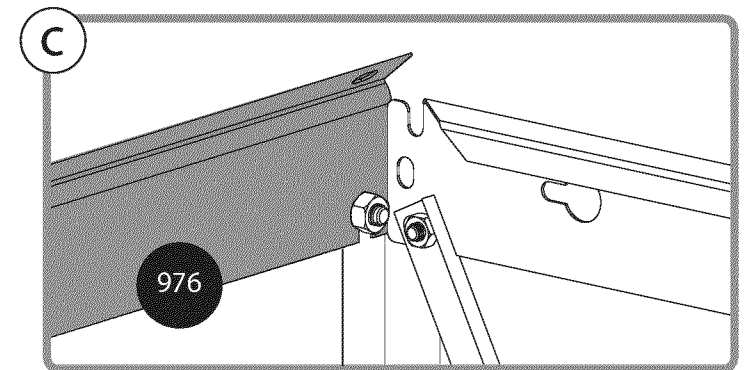
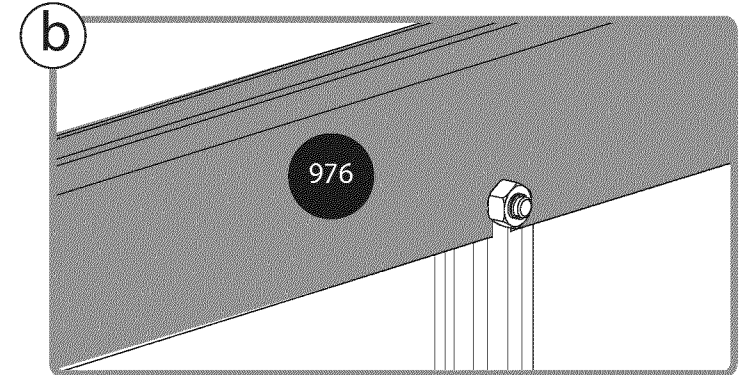
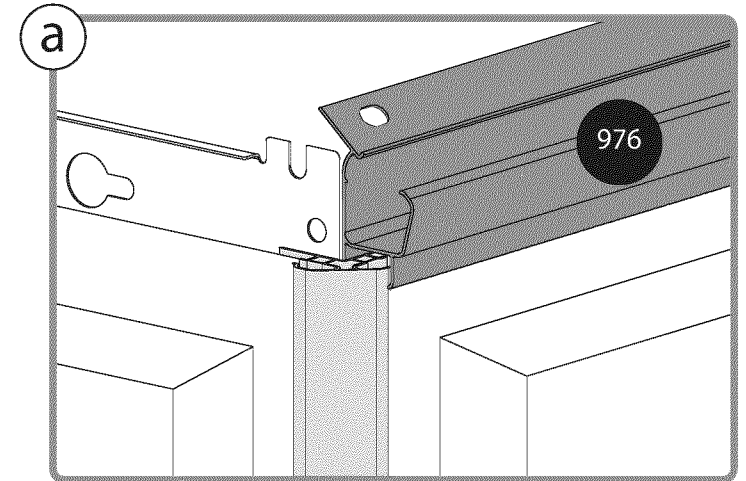
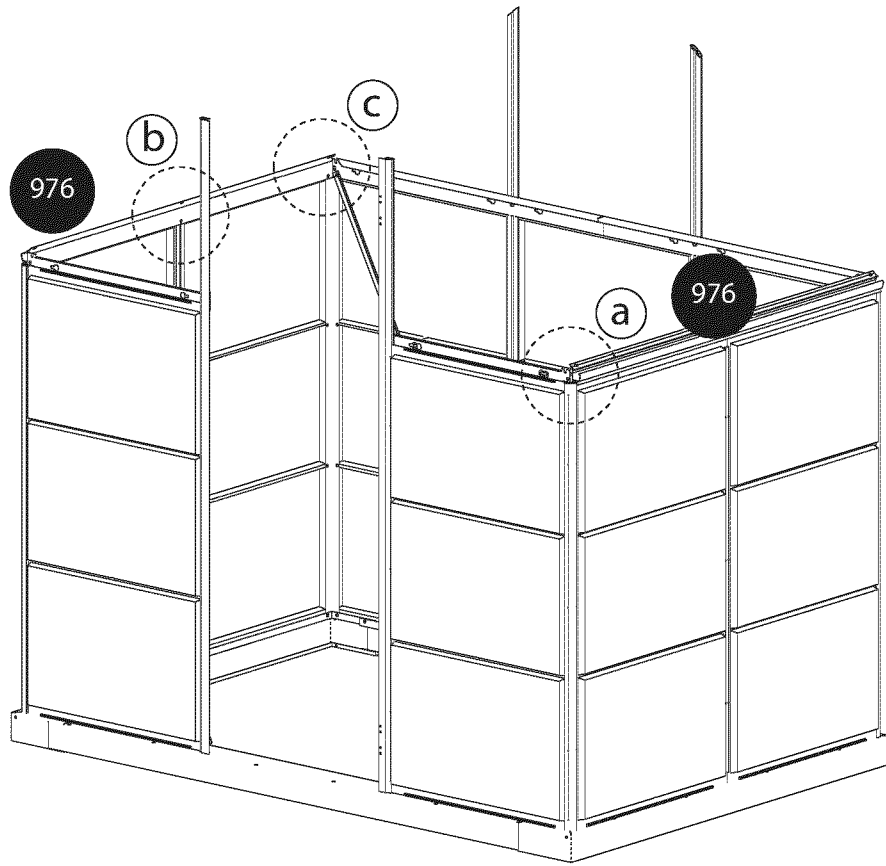
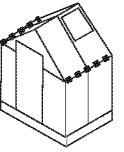

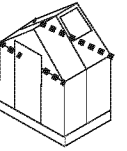

999

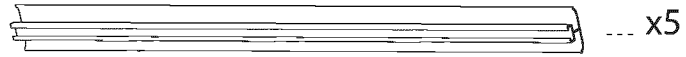

411

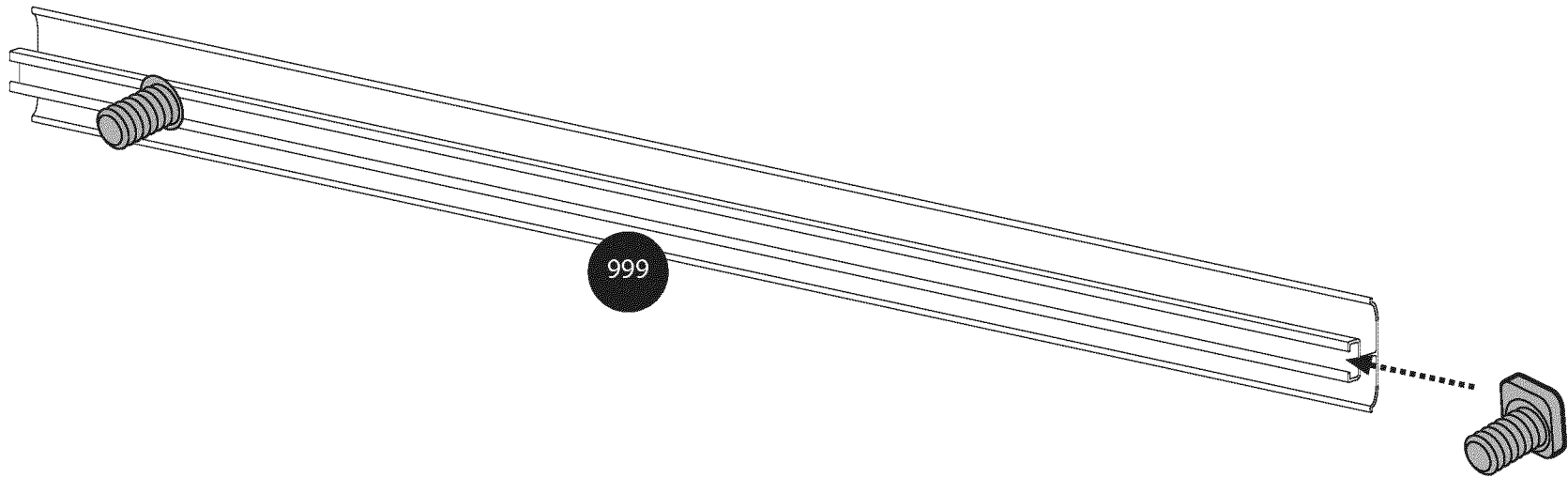
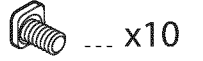

x5



412



411

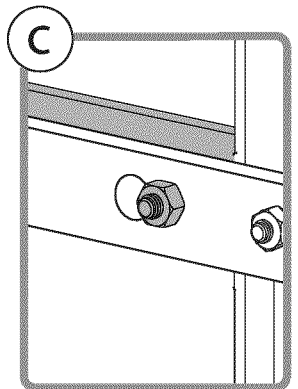
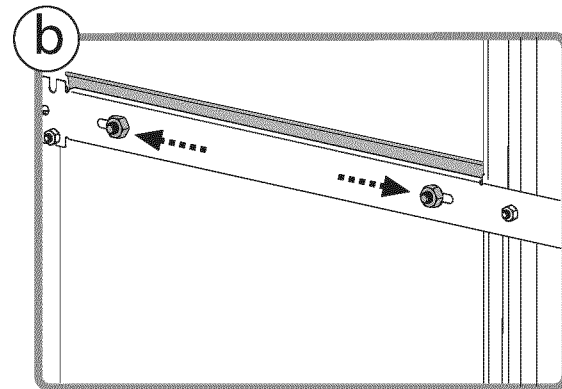
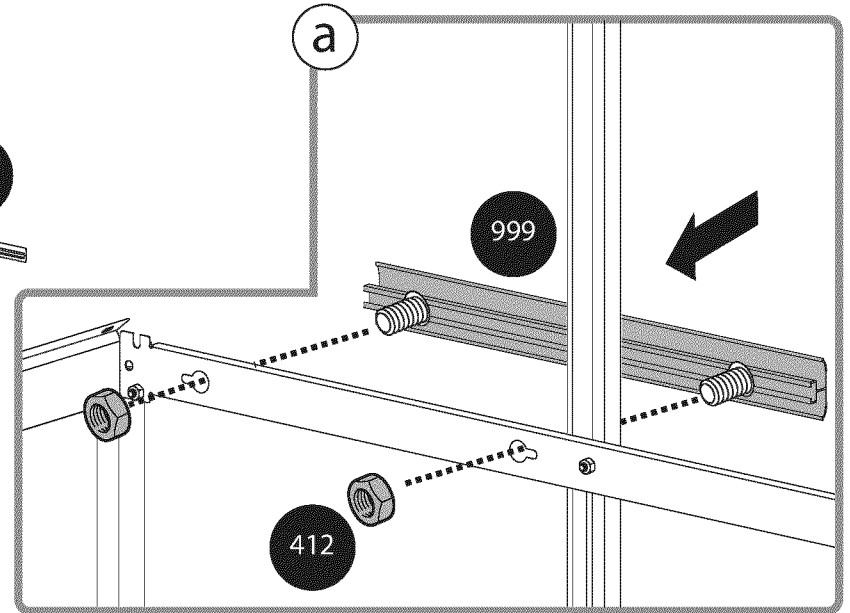
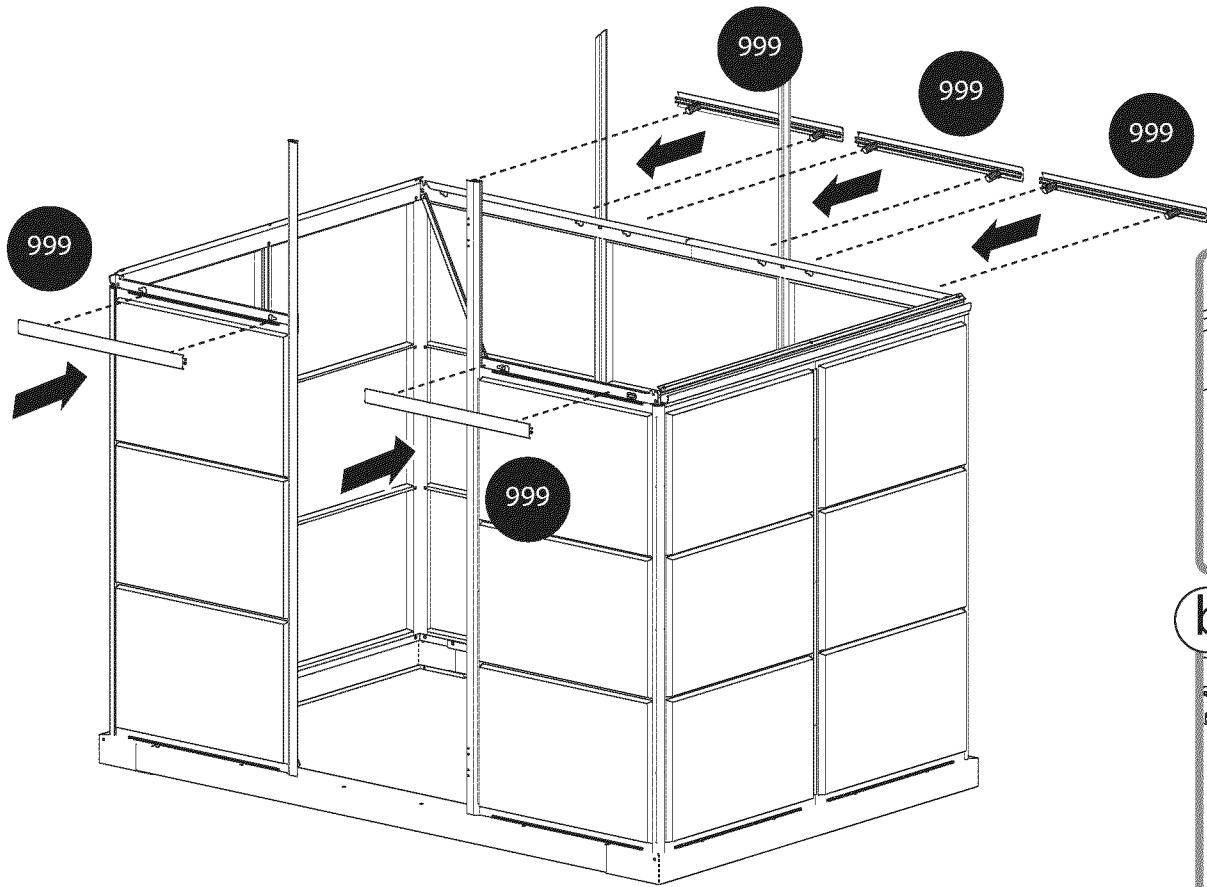
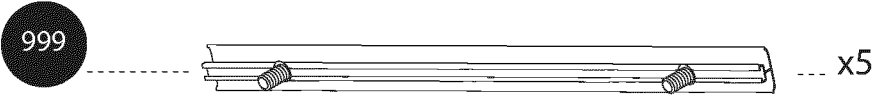
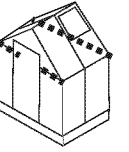

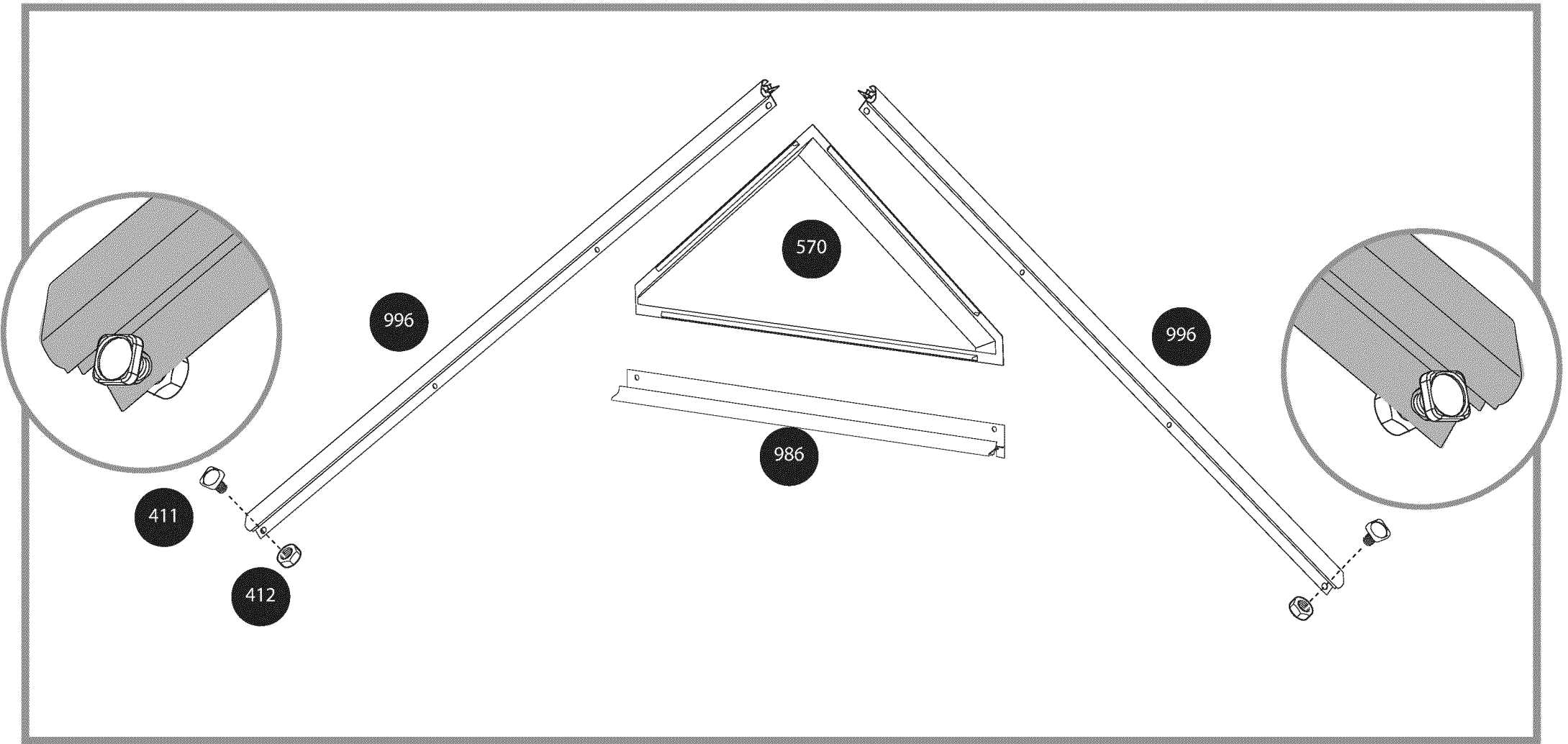
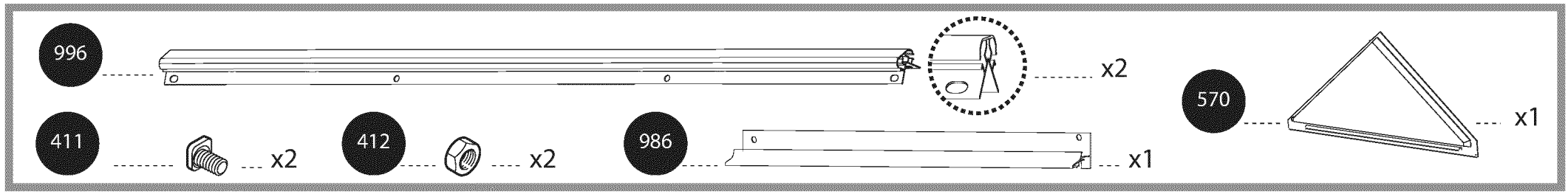
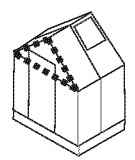

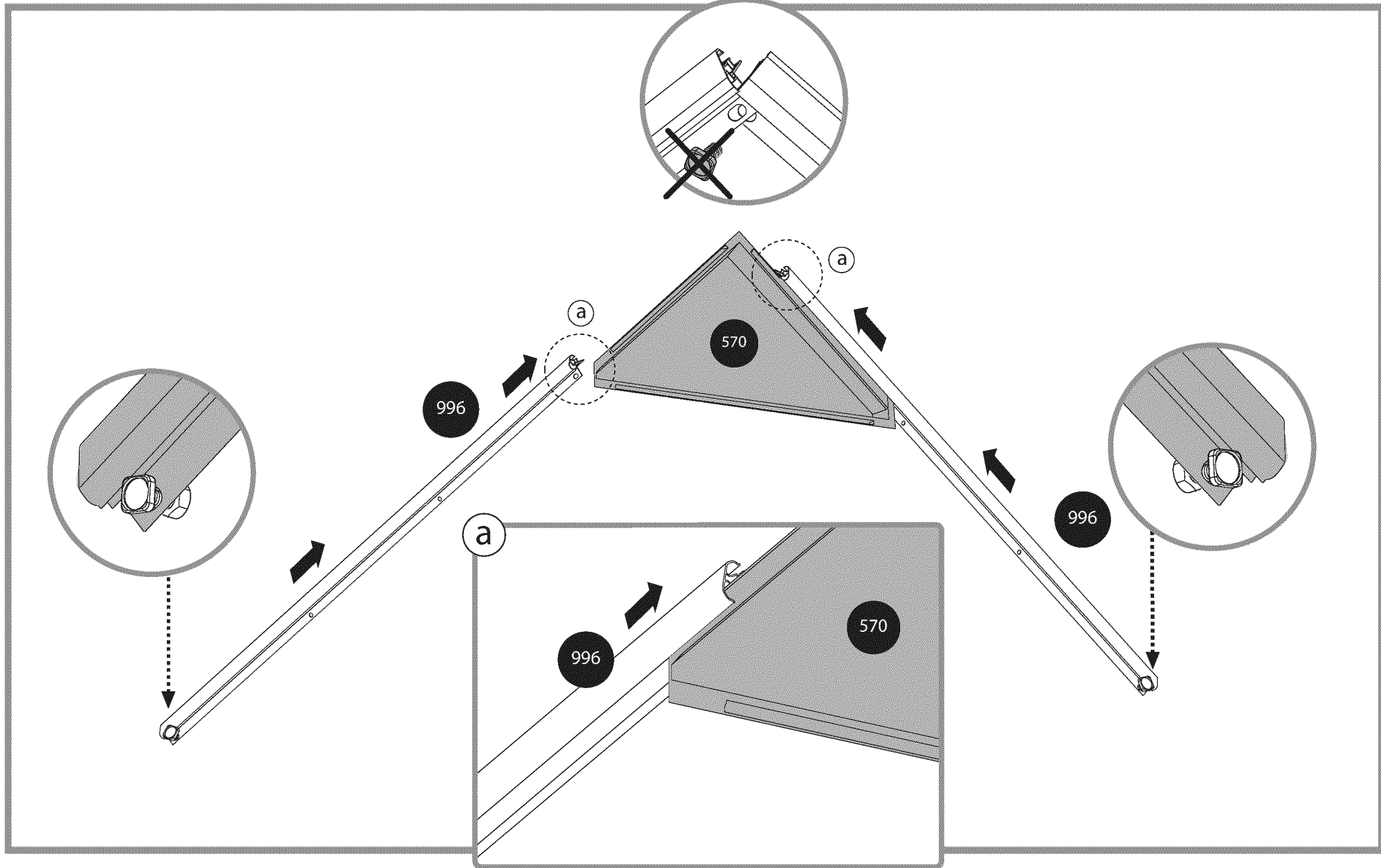
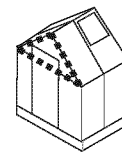

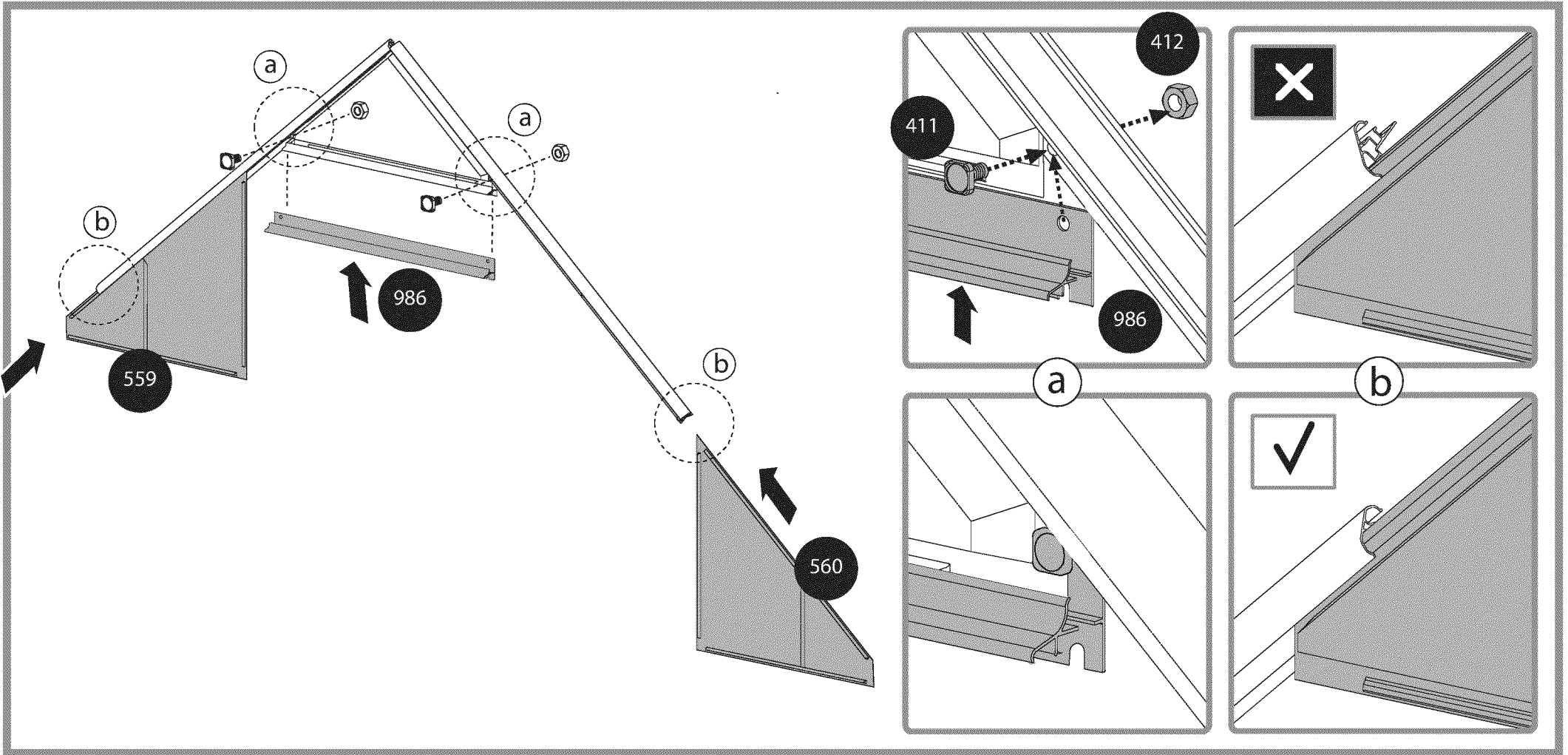
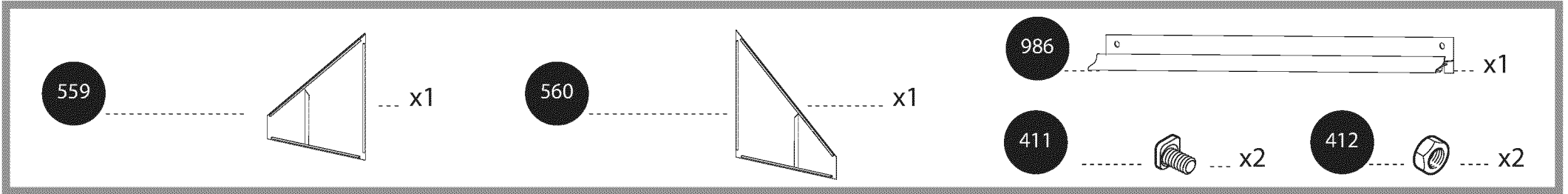
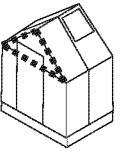

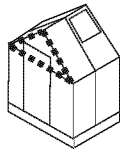

411

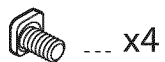

412

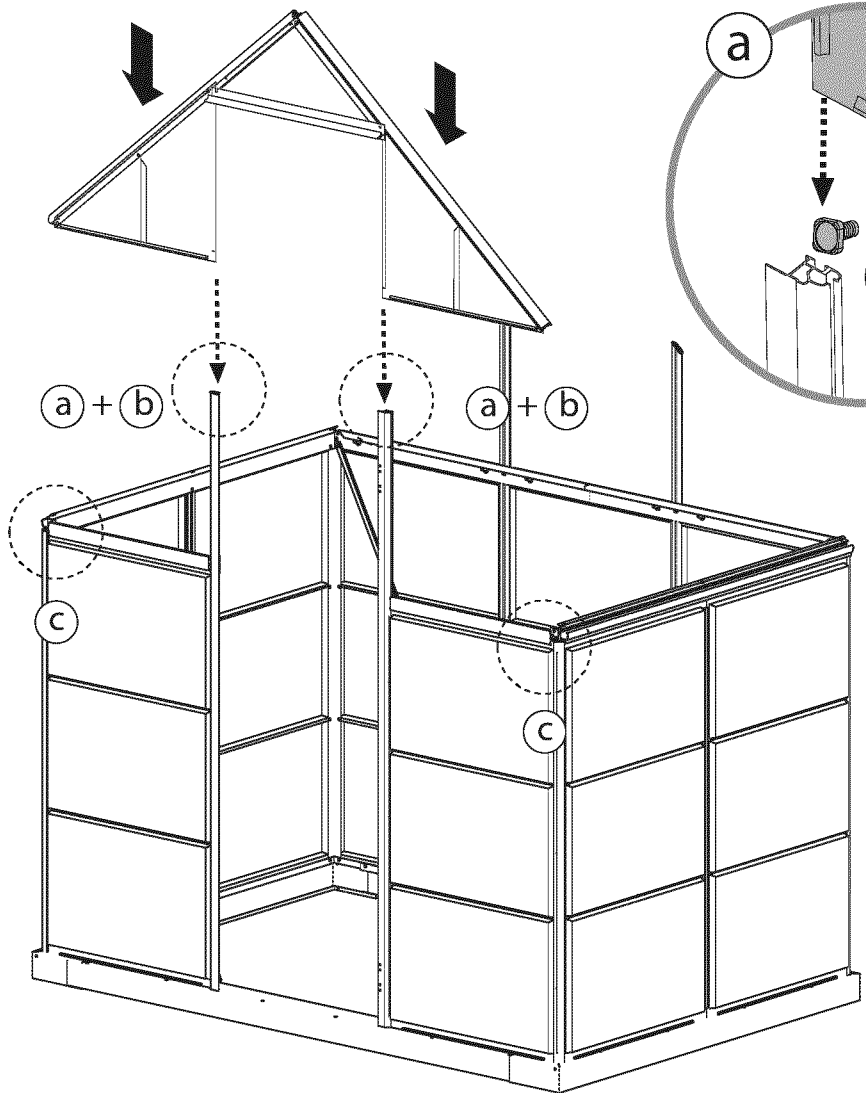

b

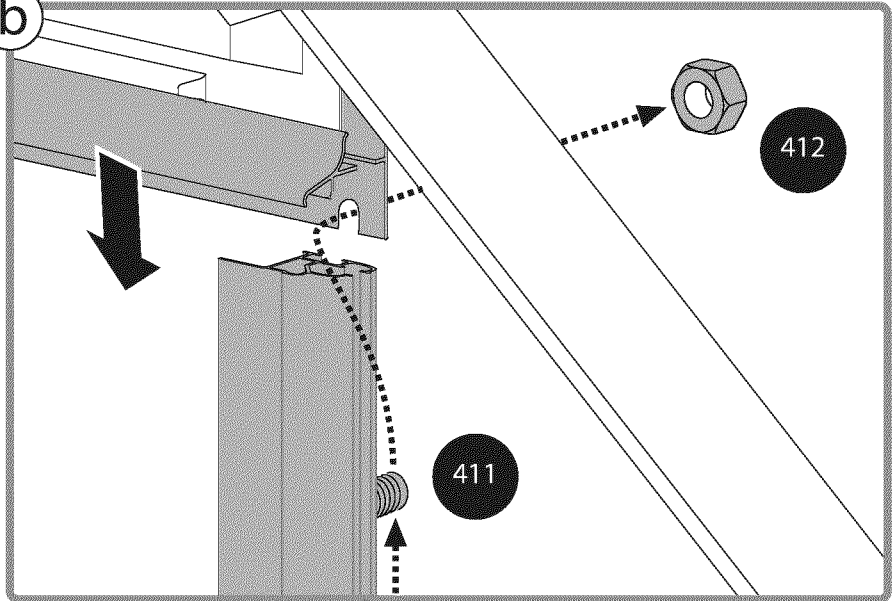

c

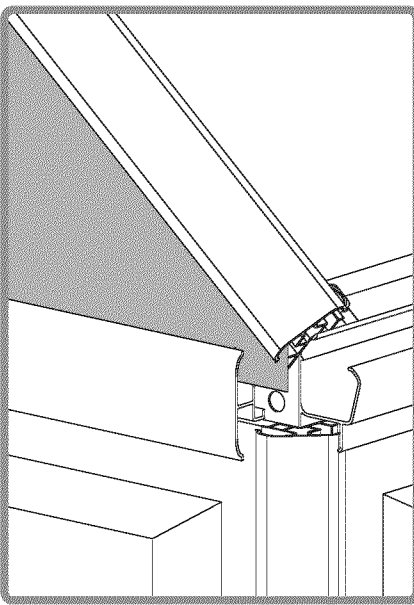
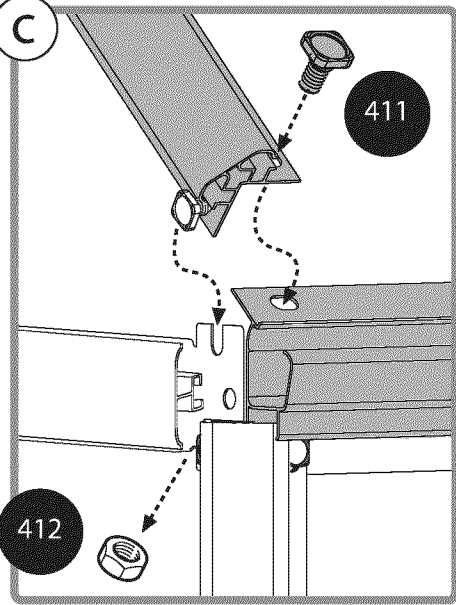

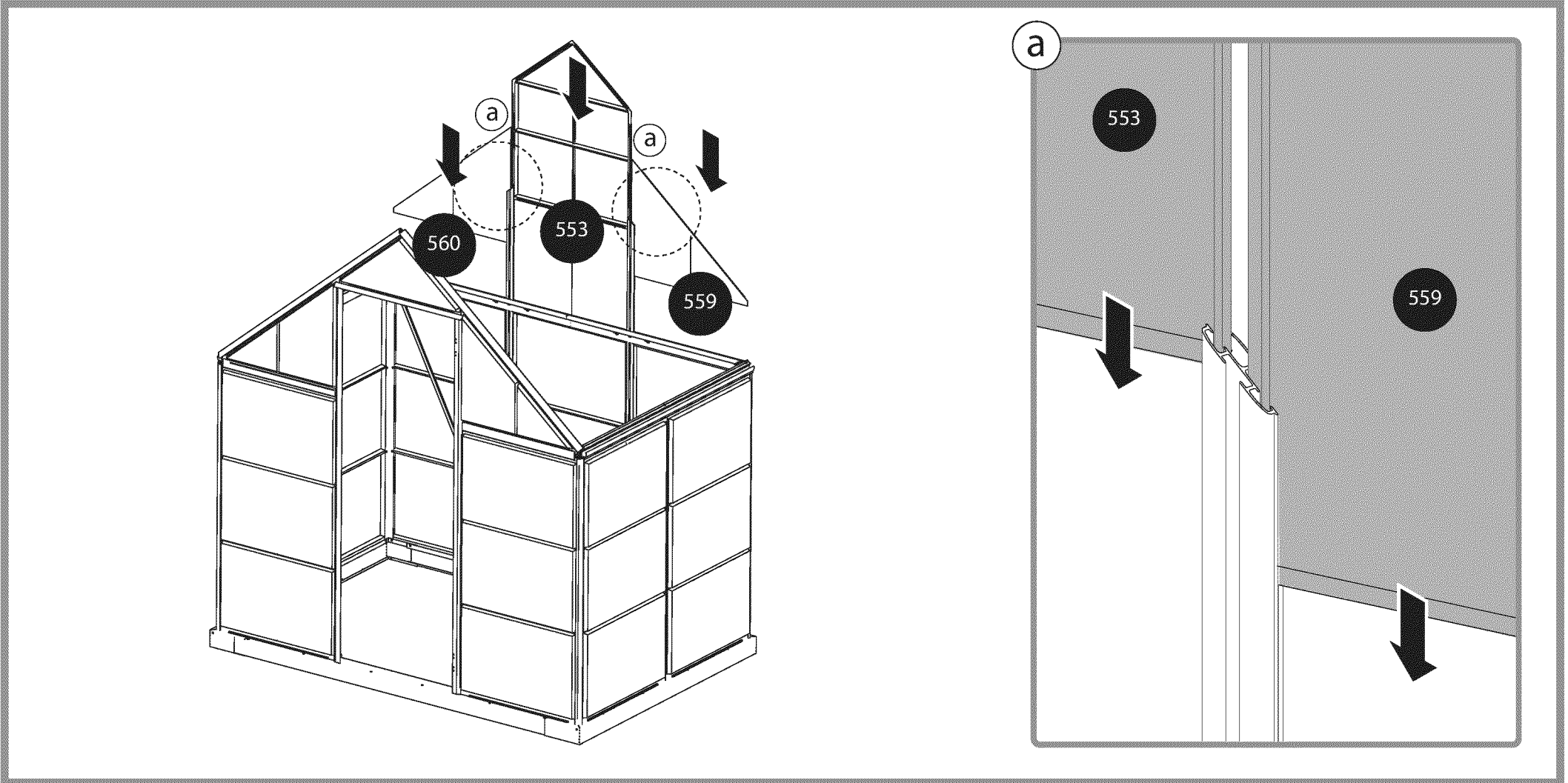
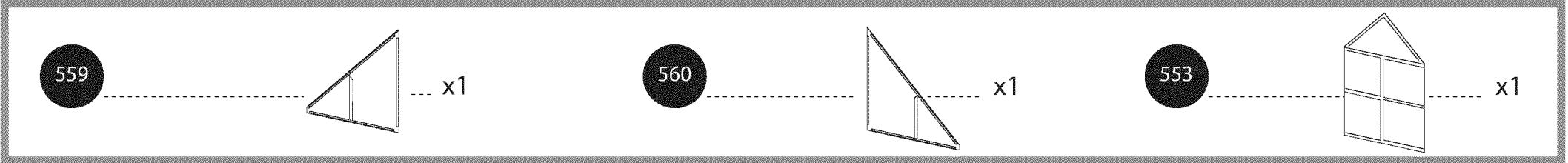
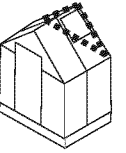

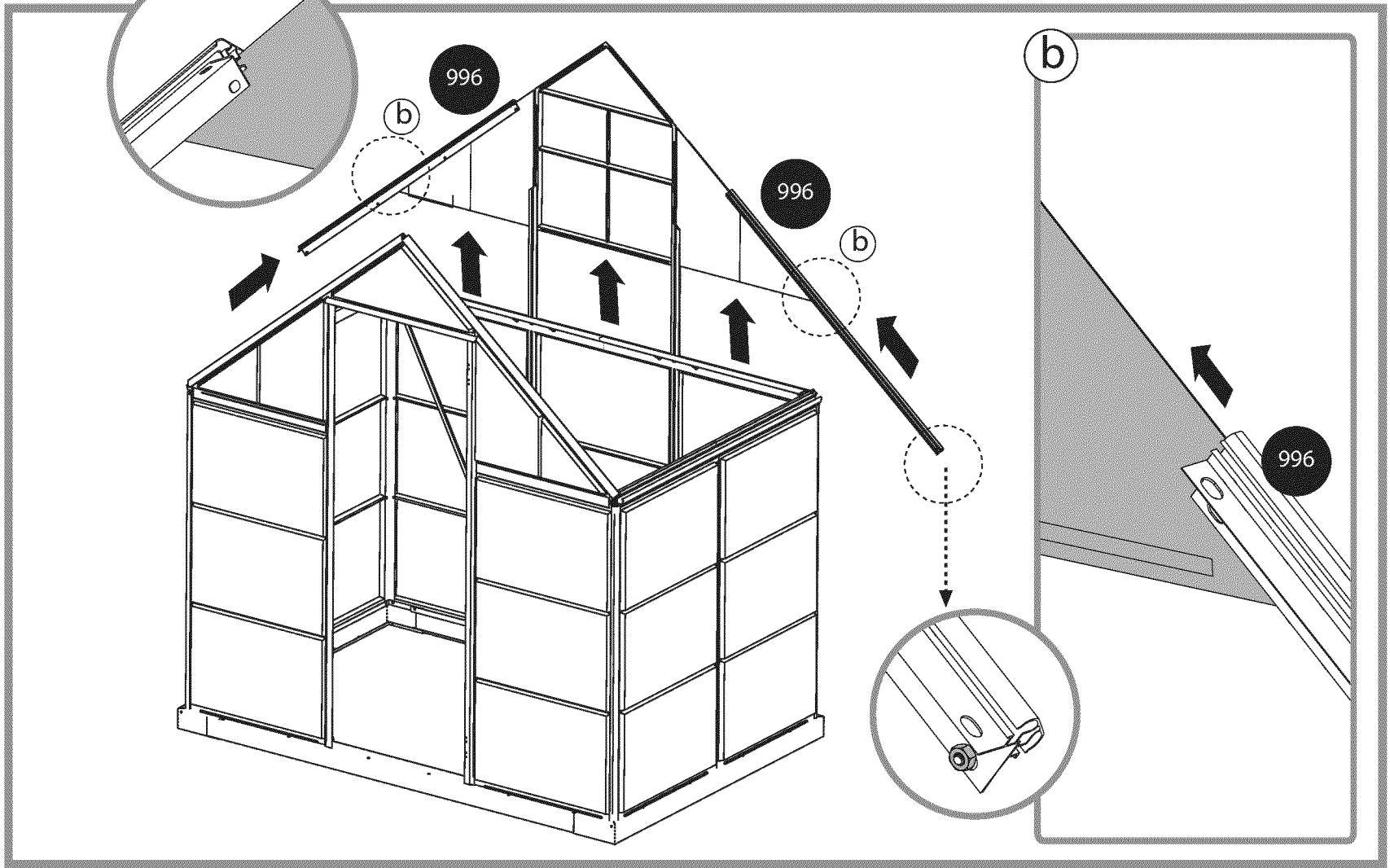
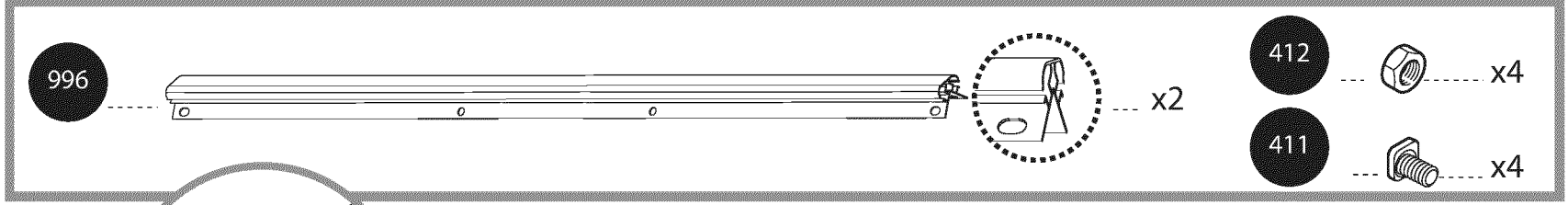
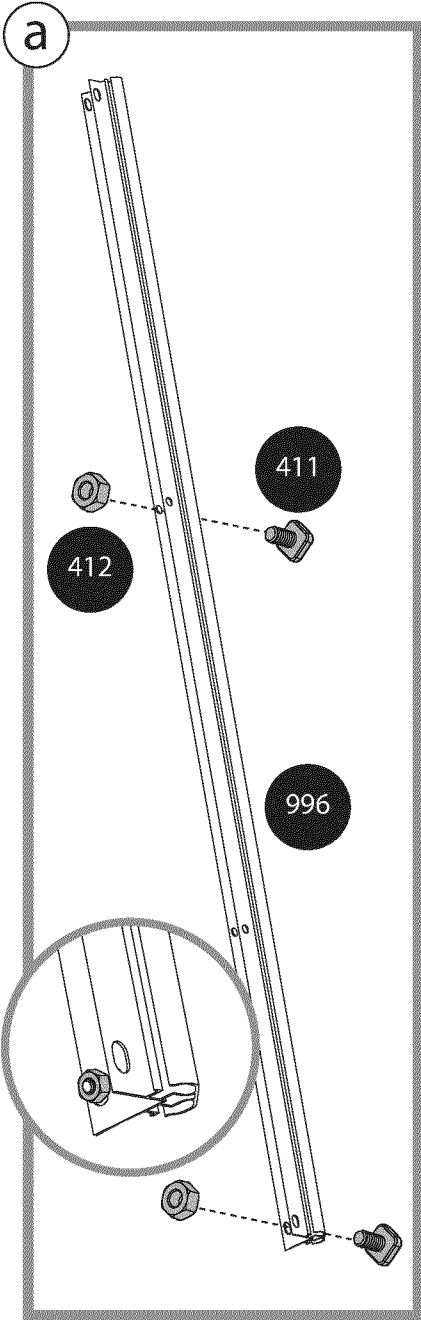
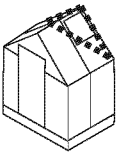

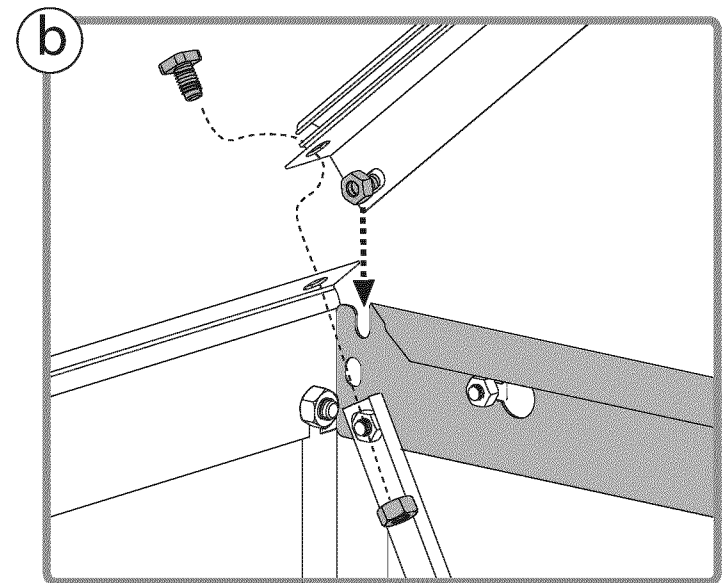
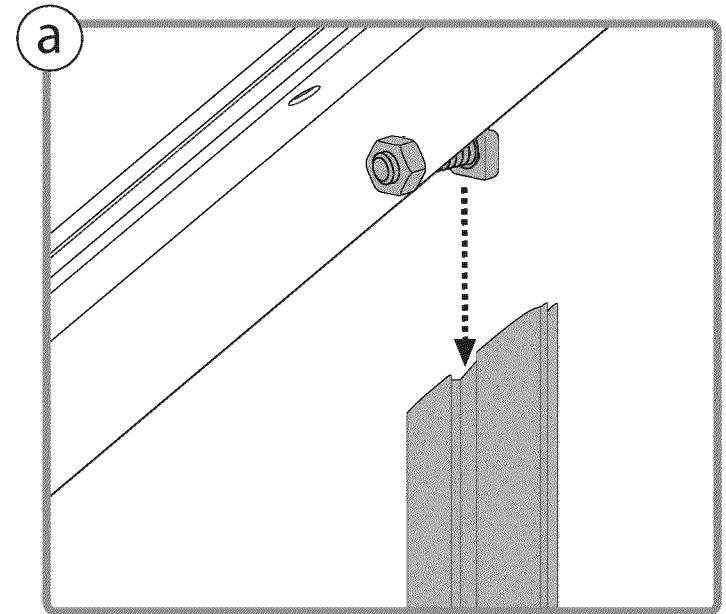
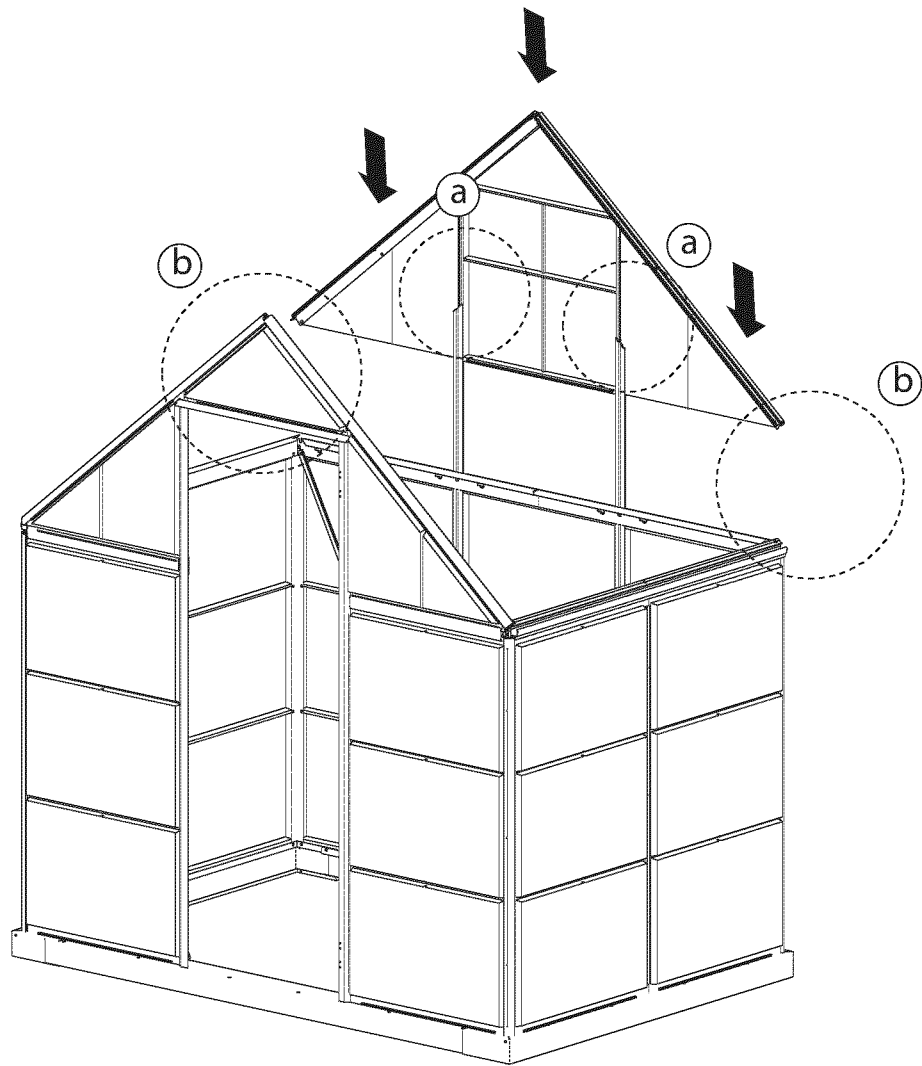
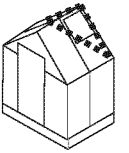

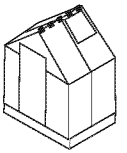

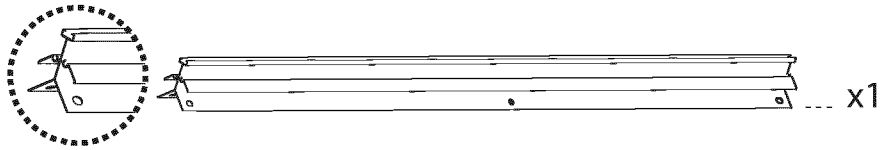

977



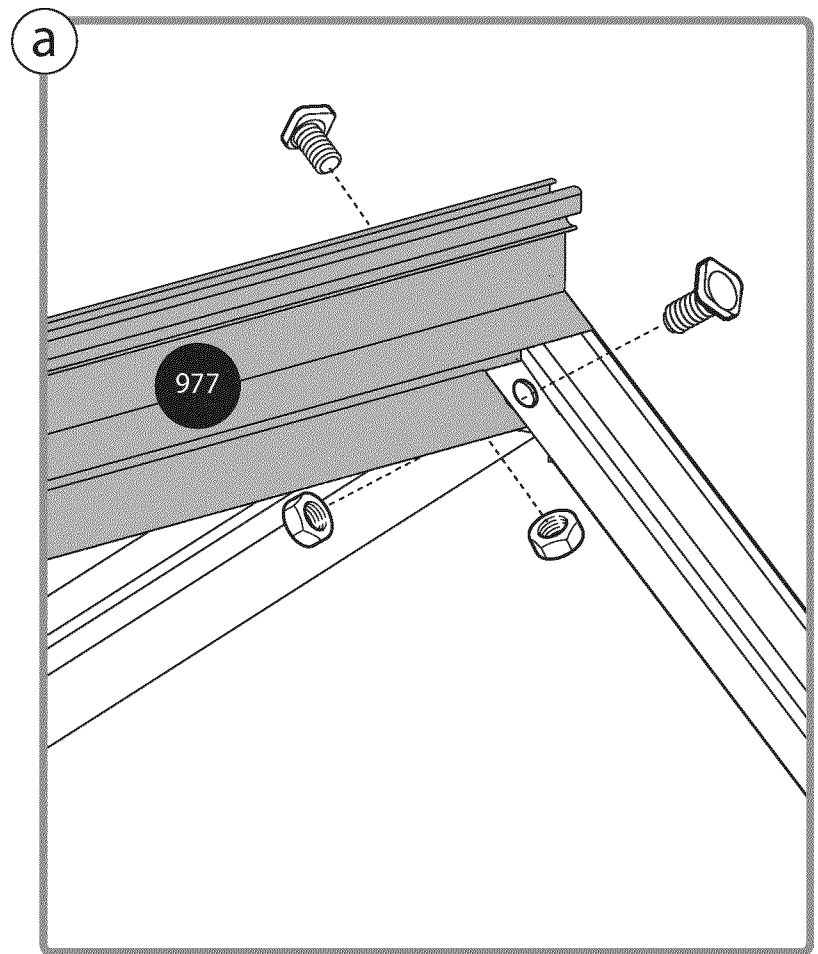
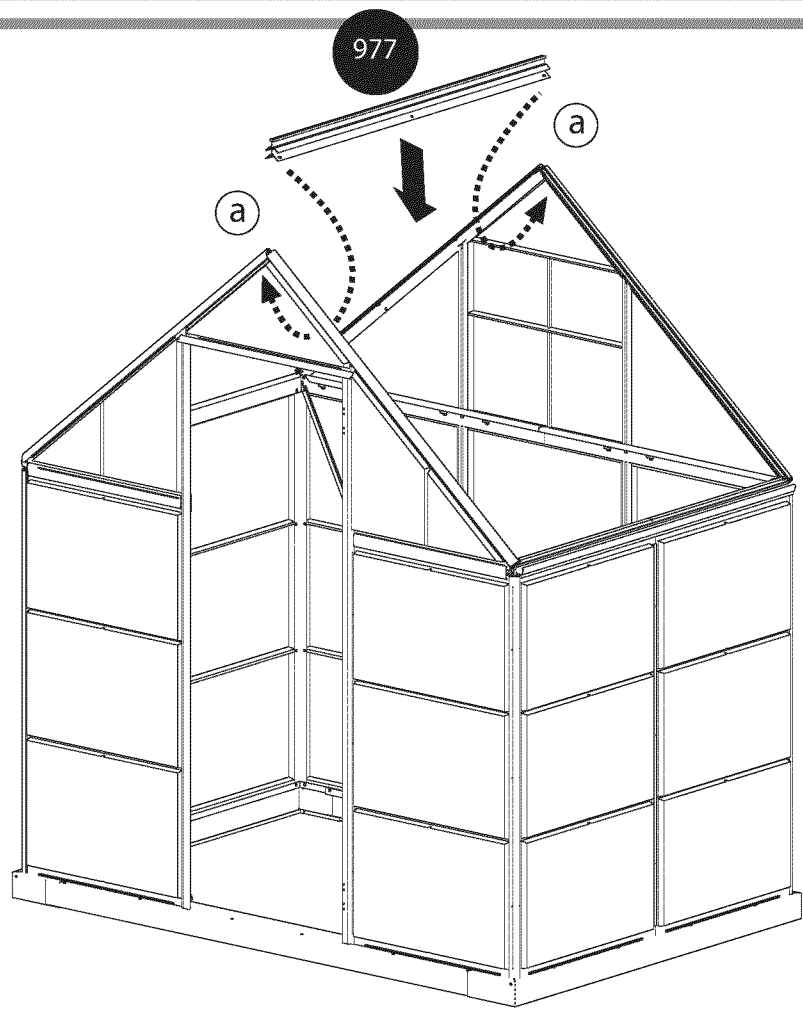

- 412  x4
- 411  x4



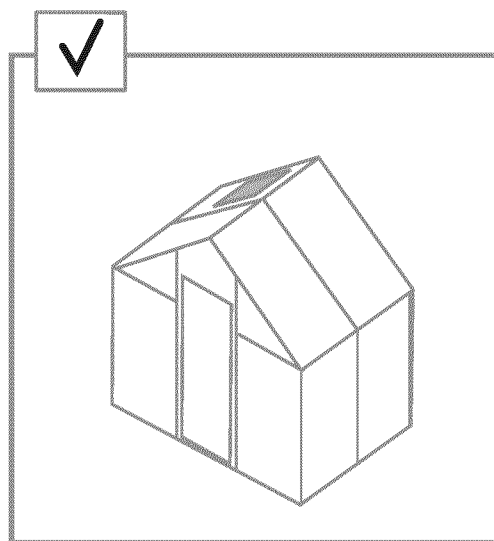
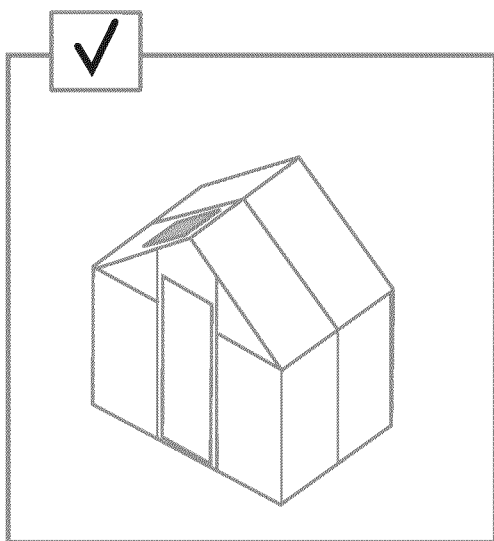
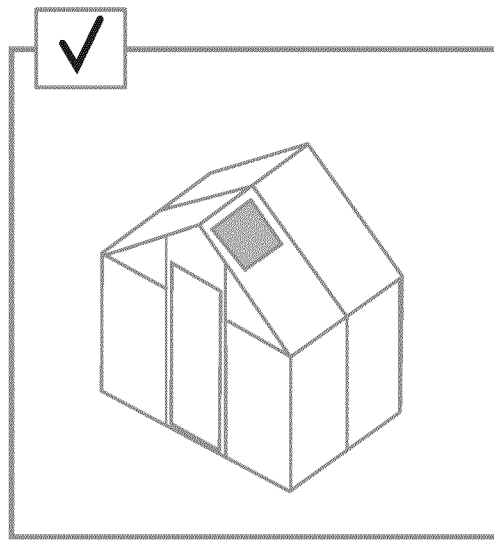
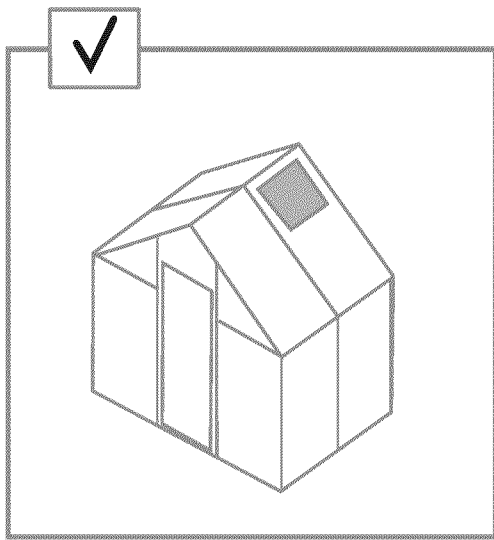
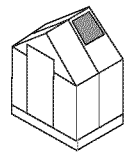

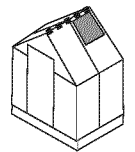
EN Window Location
GR Fenster Standort
FR Fenêtre Emplacement
SP Ventana Ubicación





411  x4

412  x4

959  x1

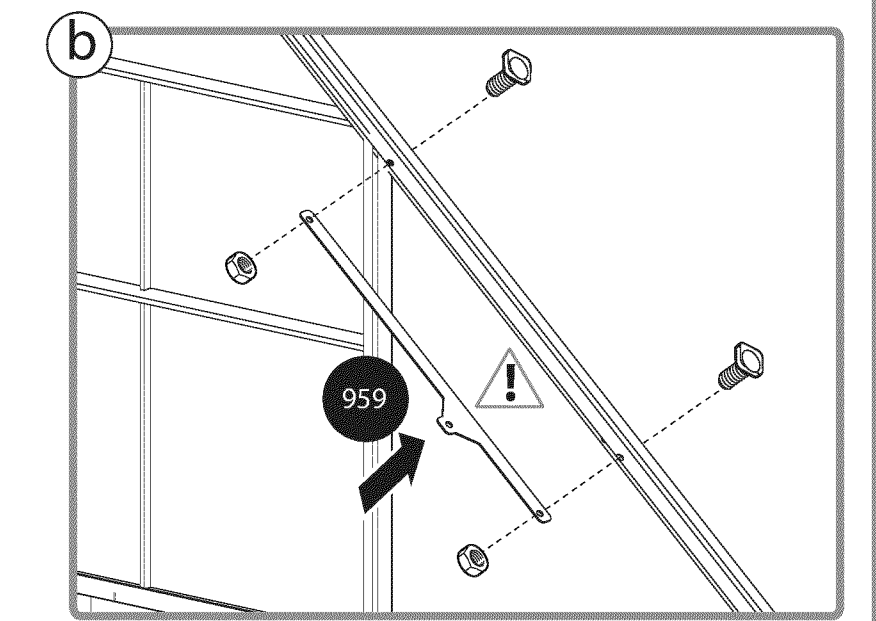
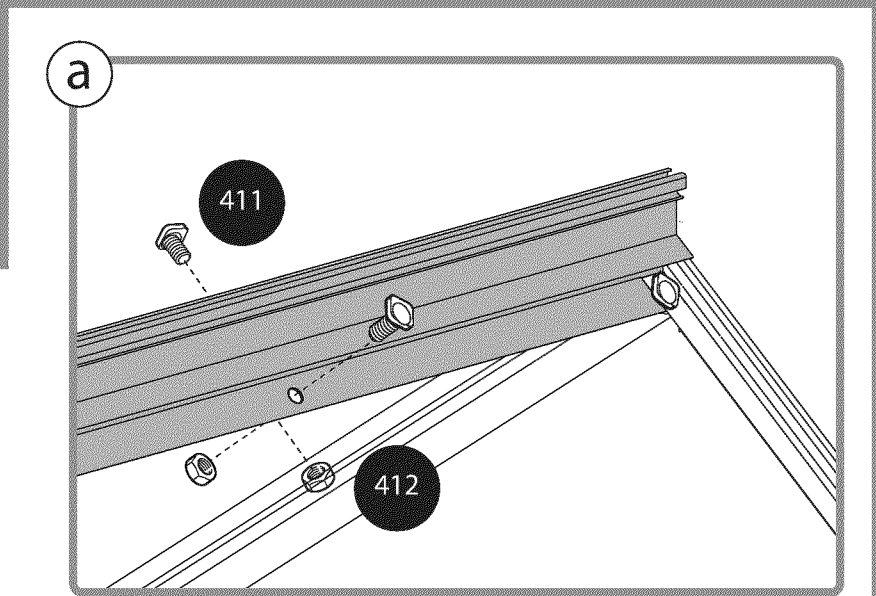
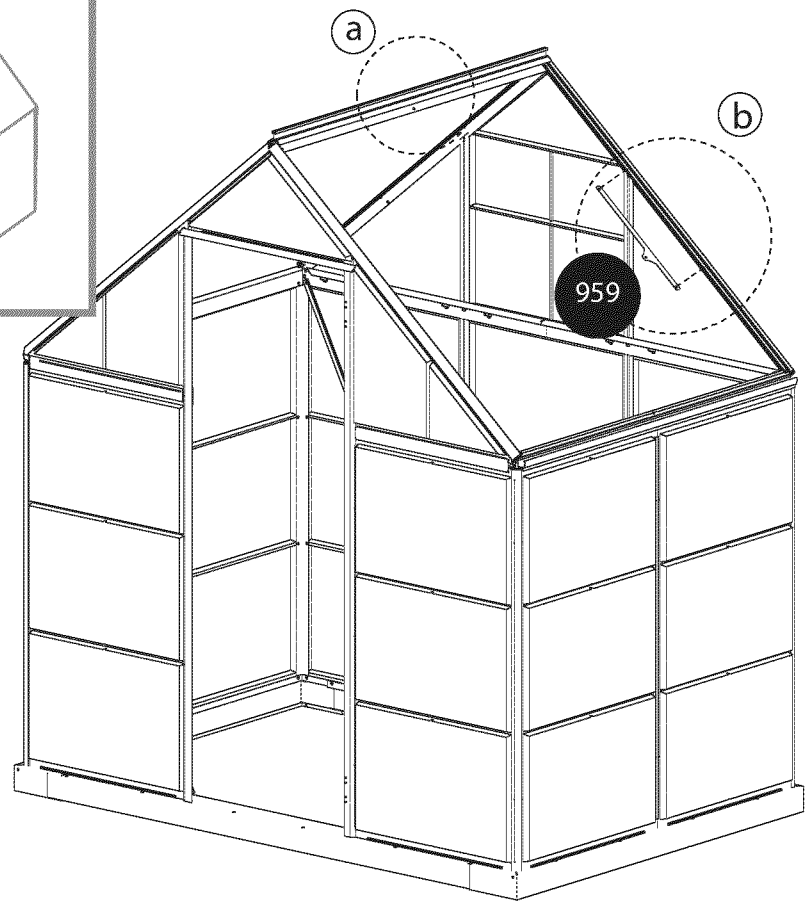
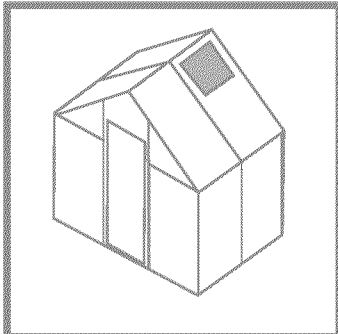

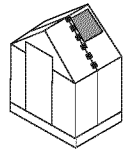

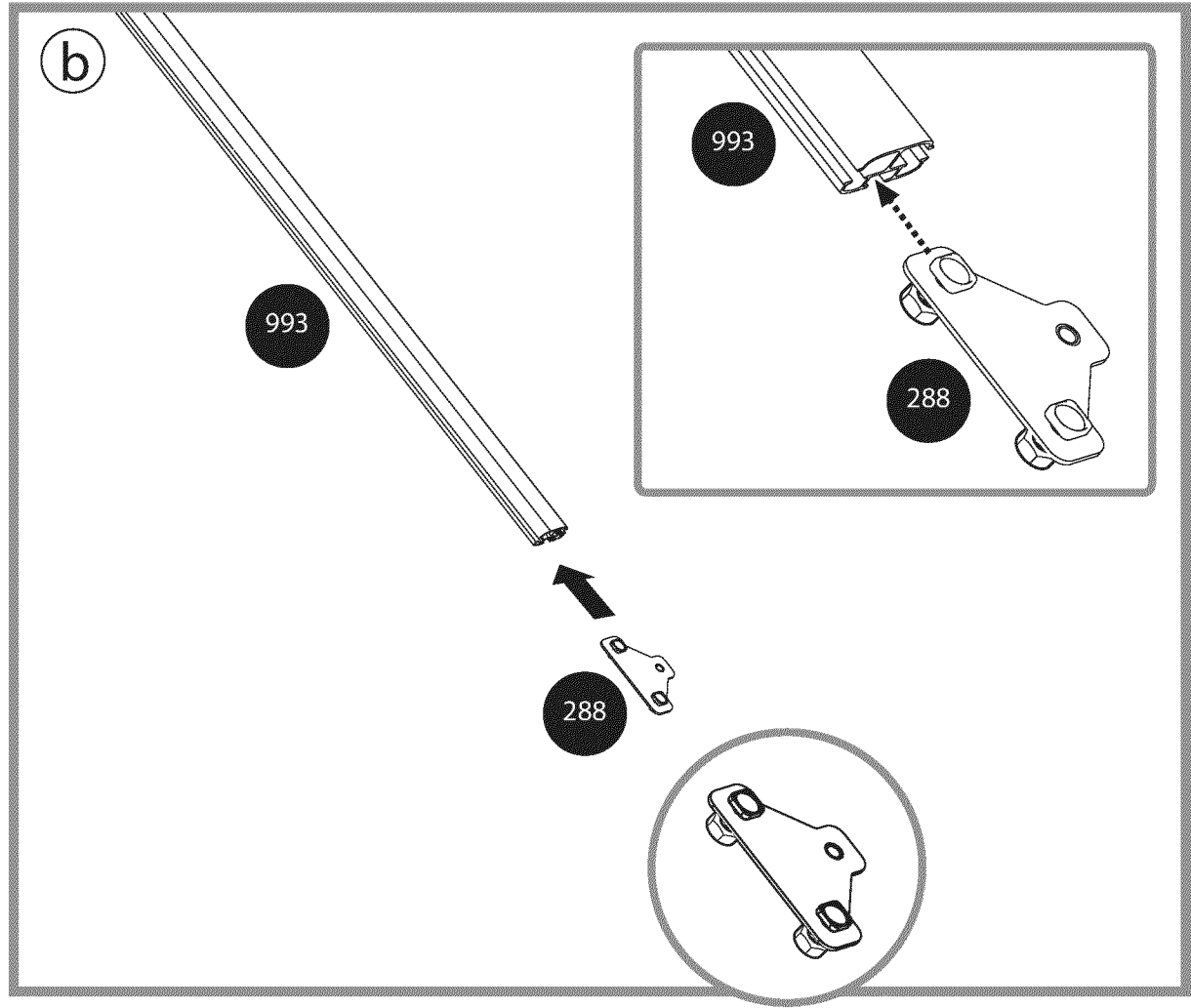
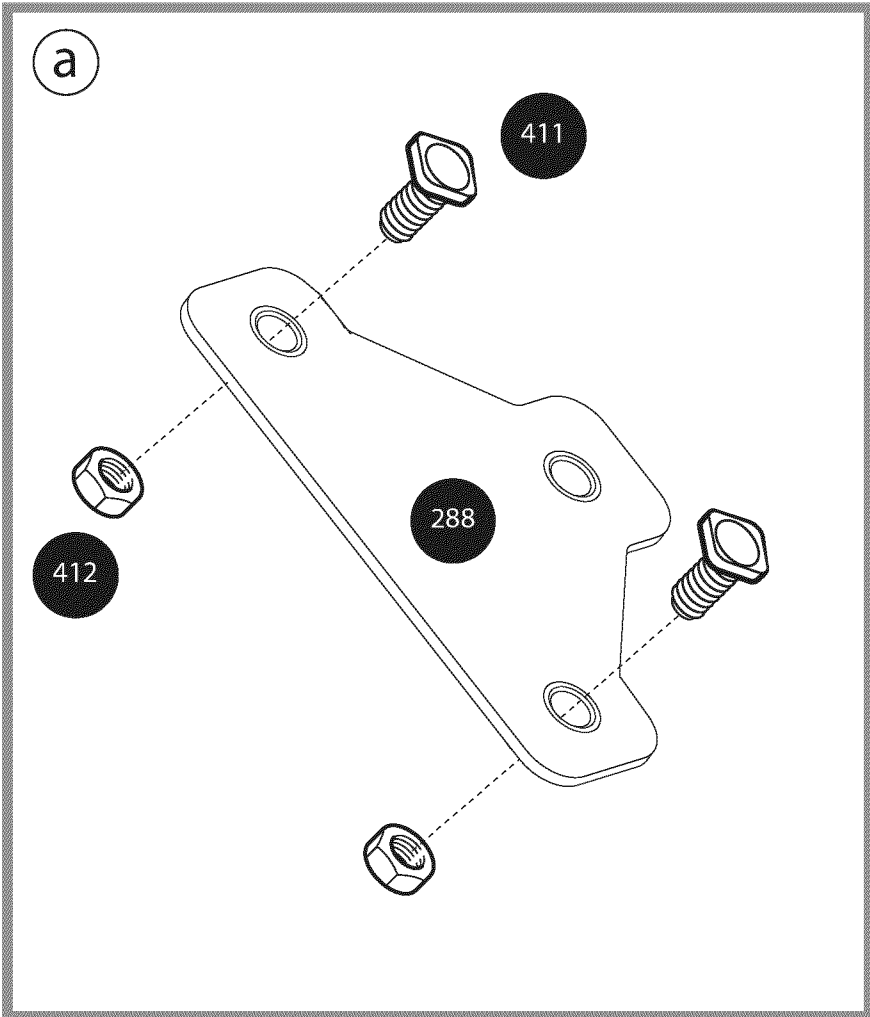

288 x1 993 x1

411 x2 412 x2

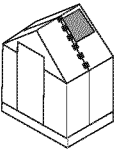



993

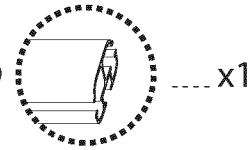
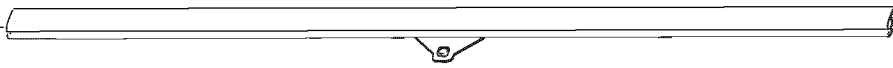

411



412

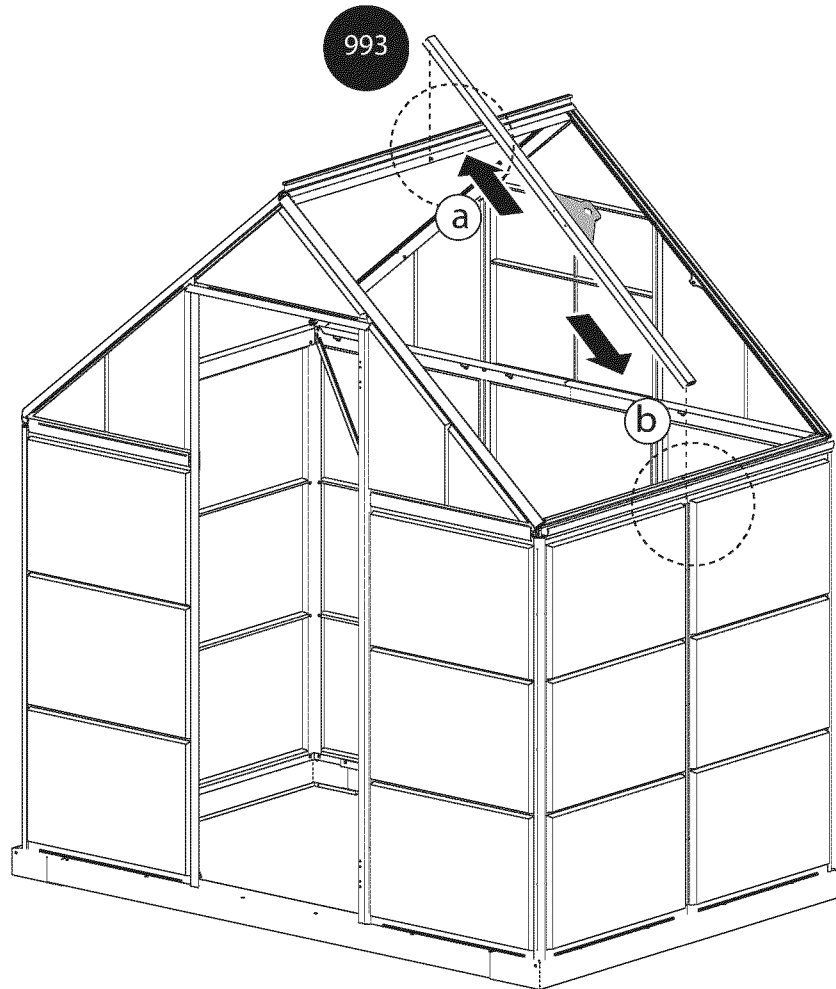

a

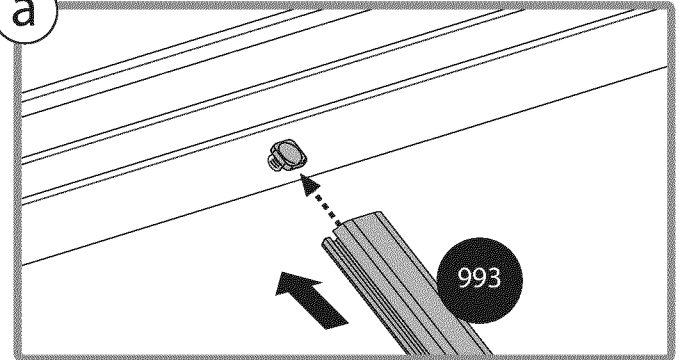

b

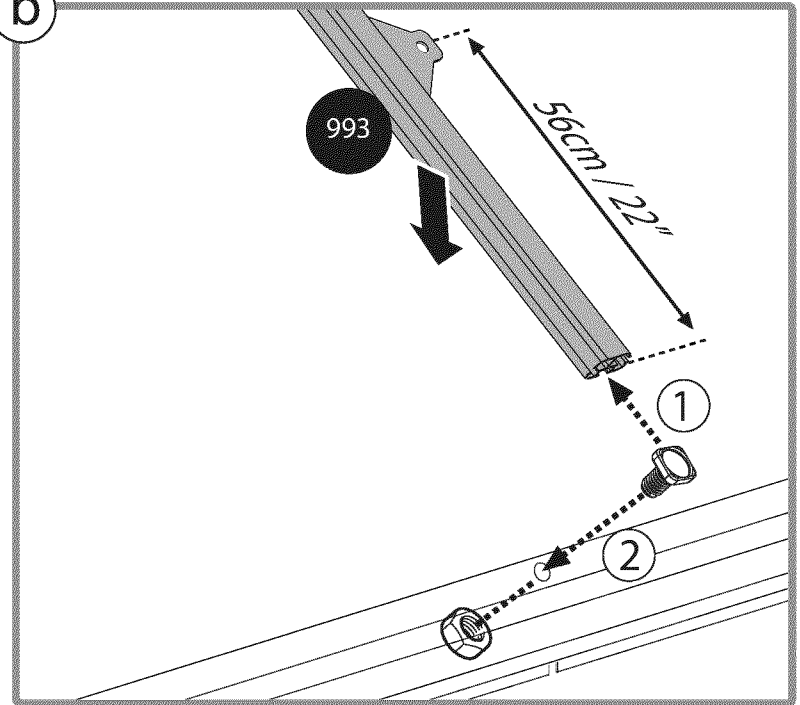

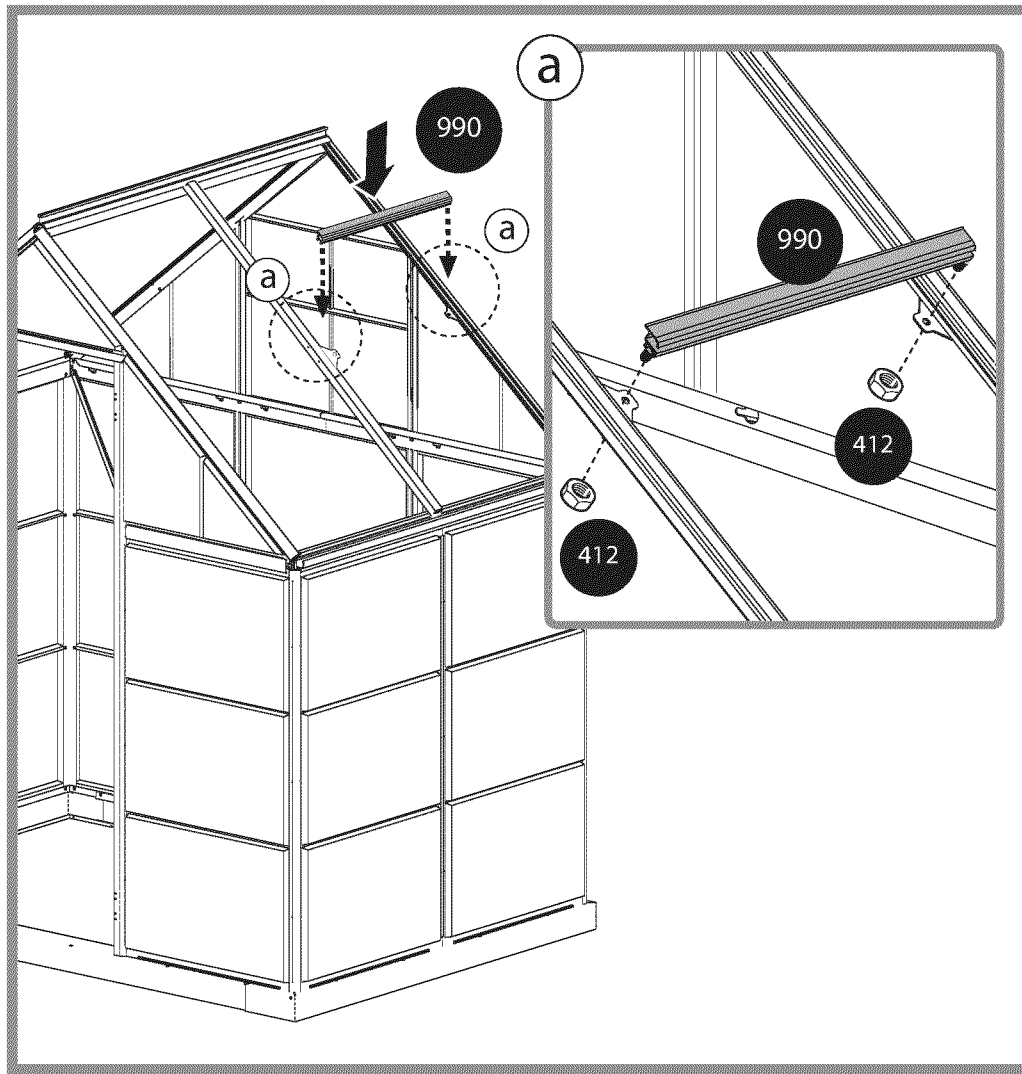
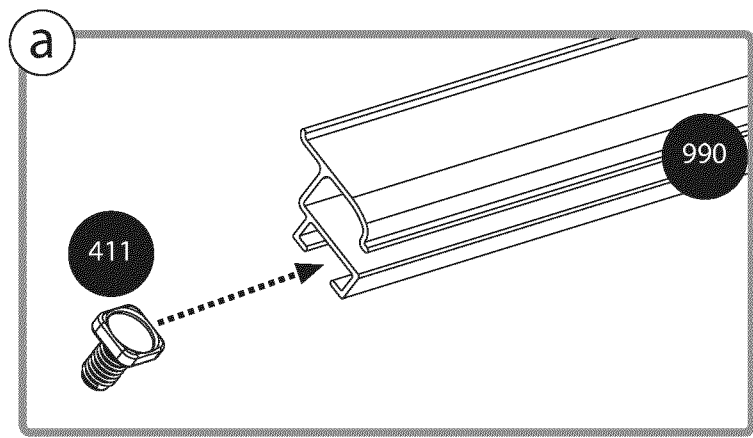
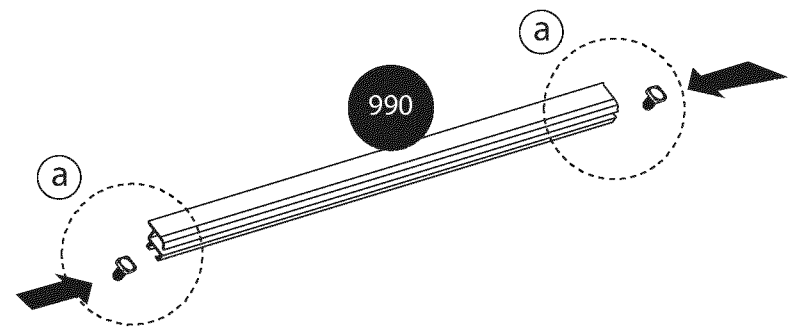
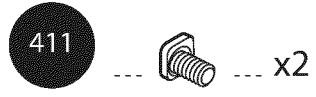
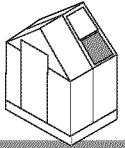

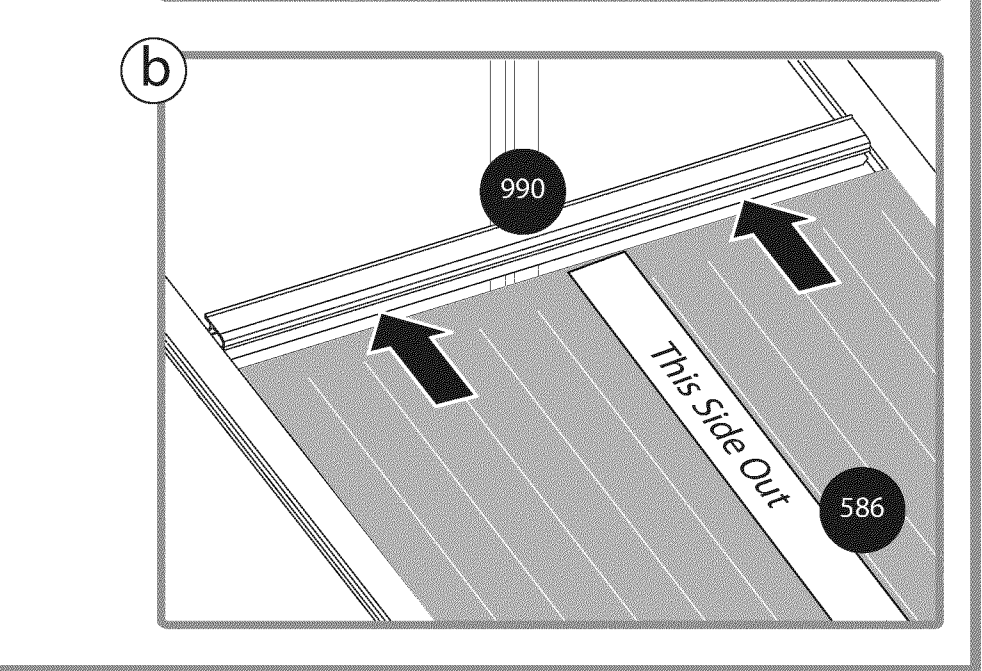
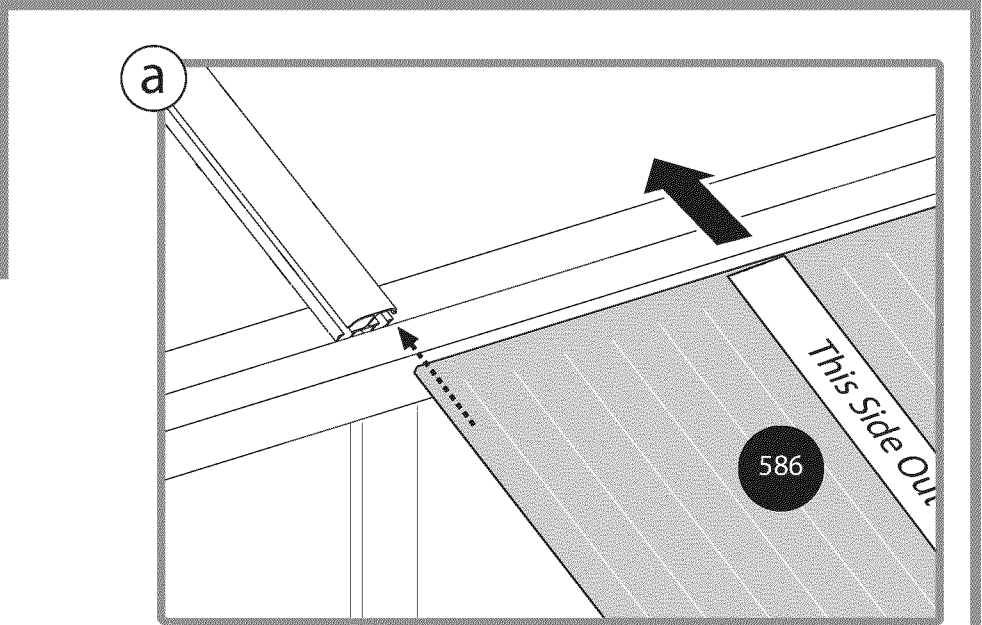
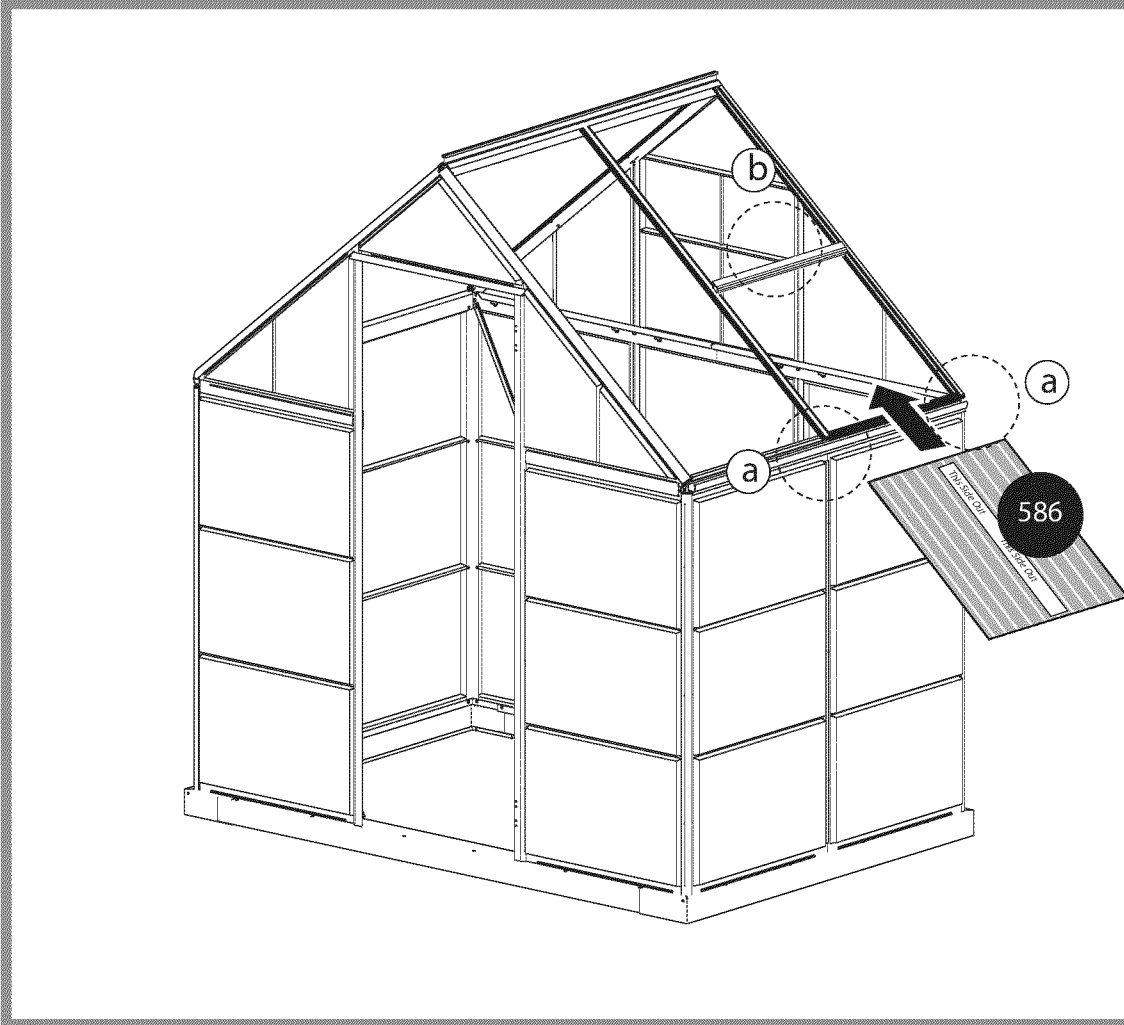
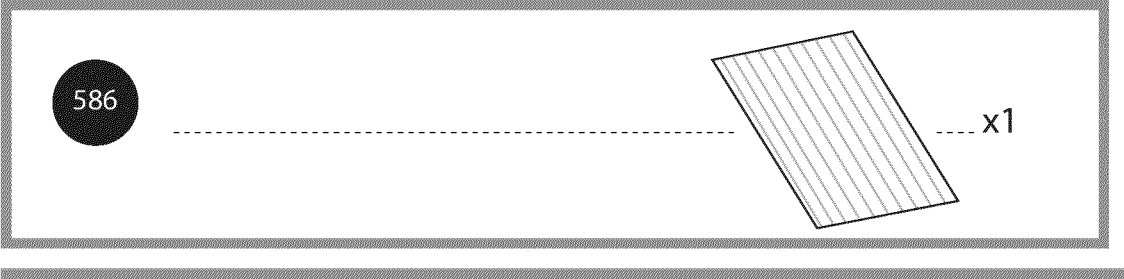
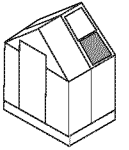

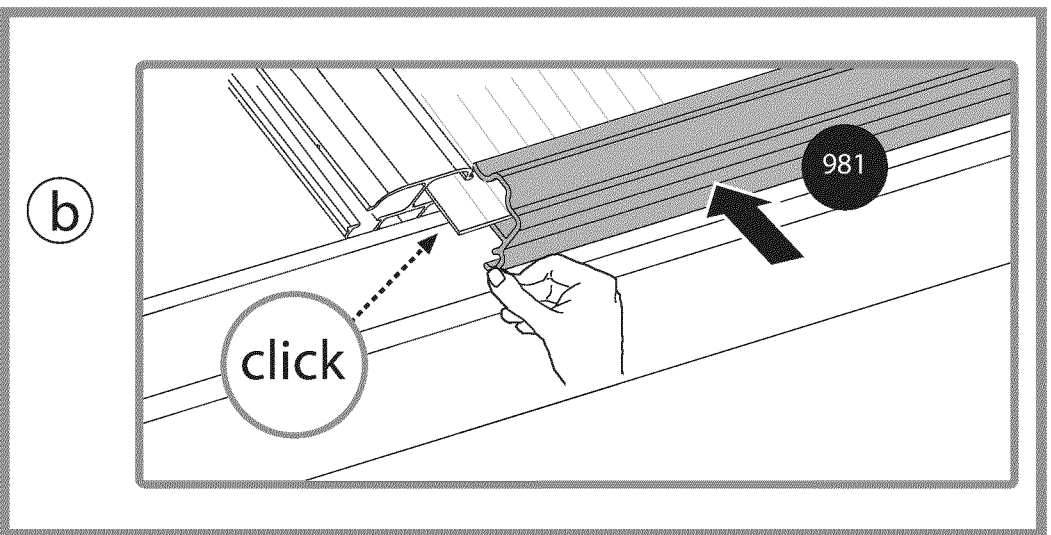
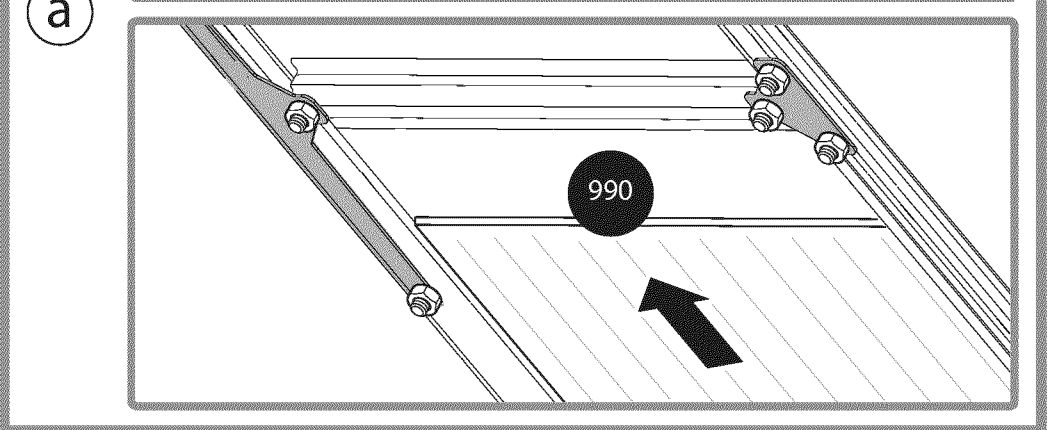
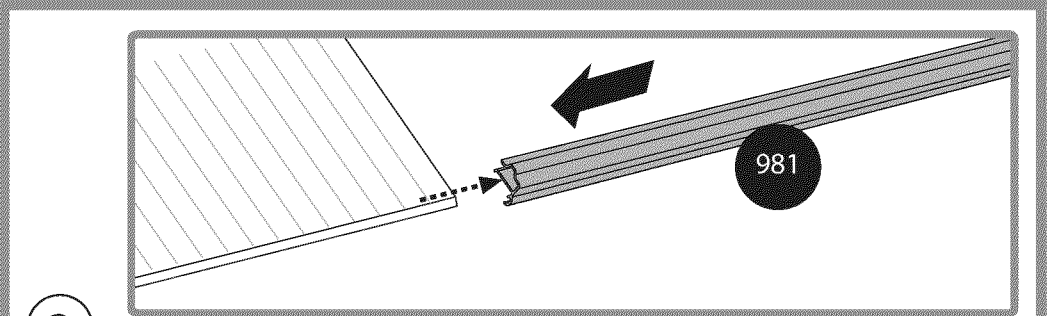
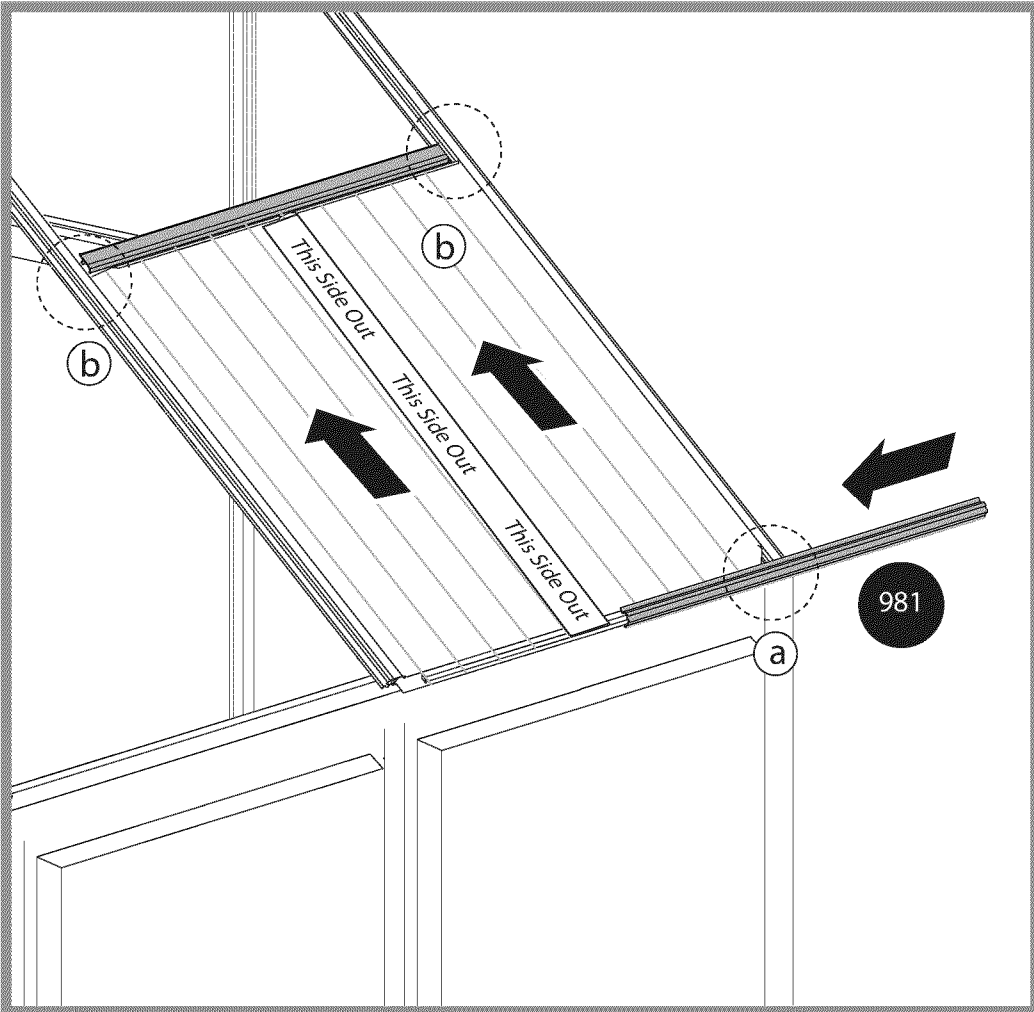
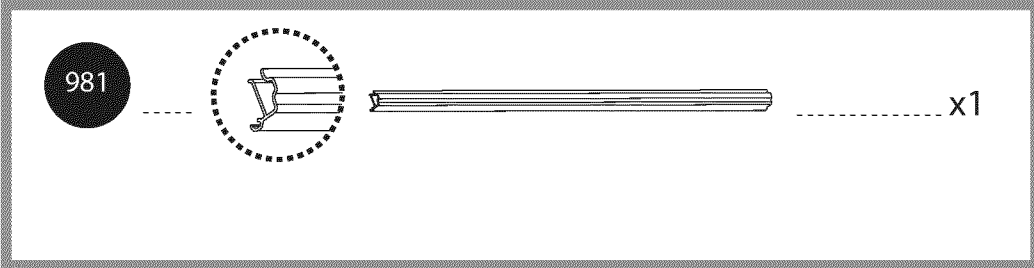
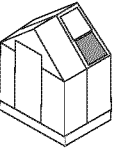

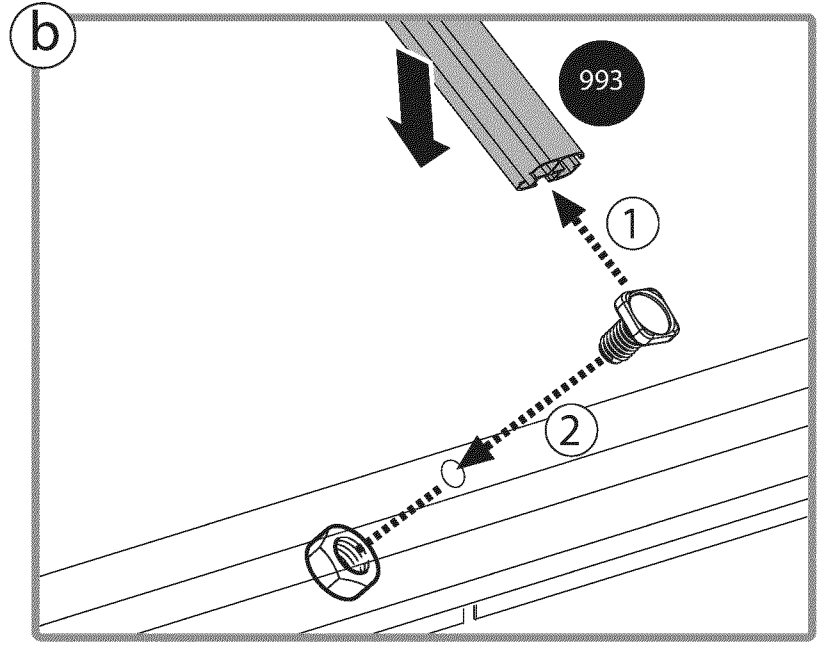
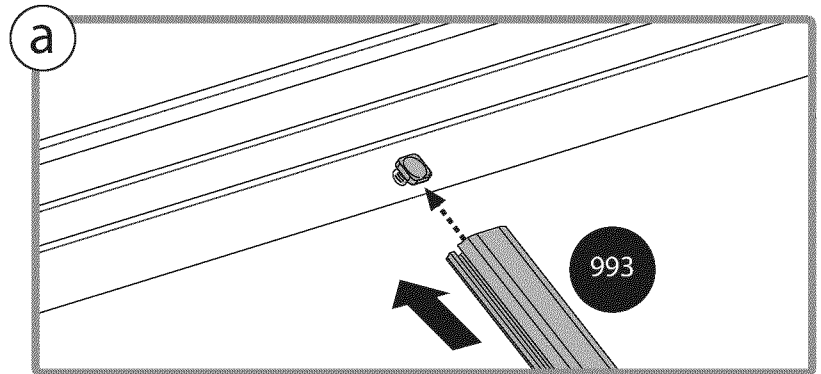
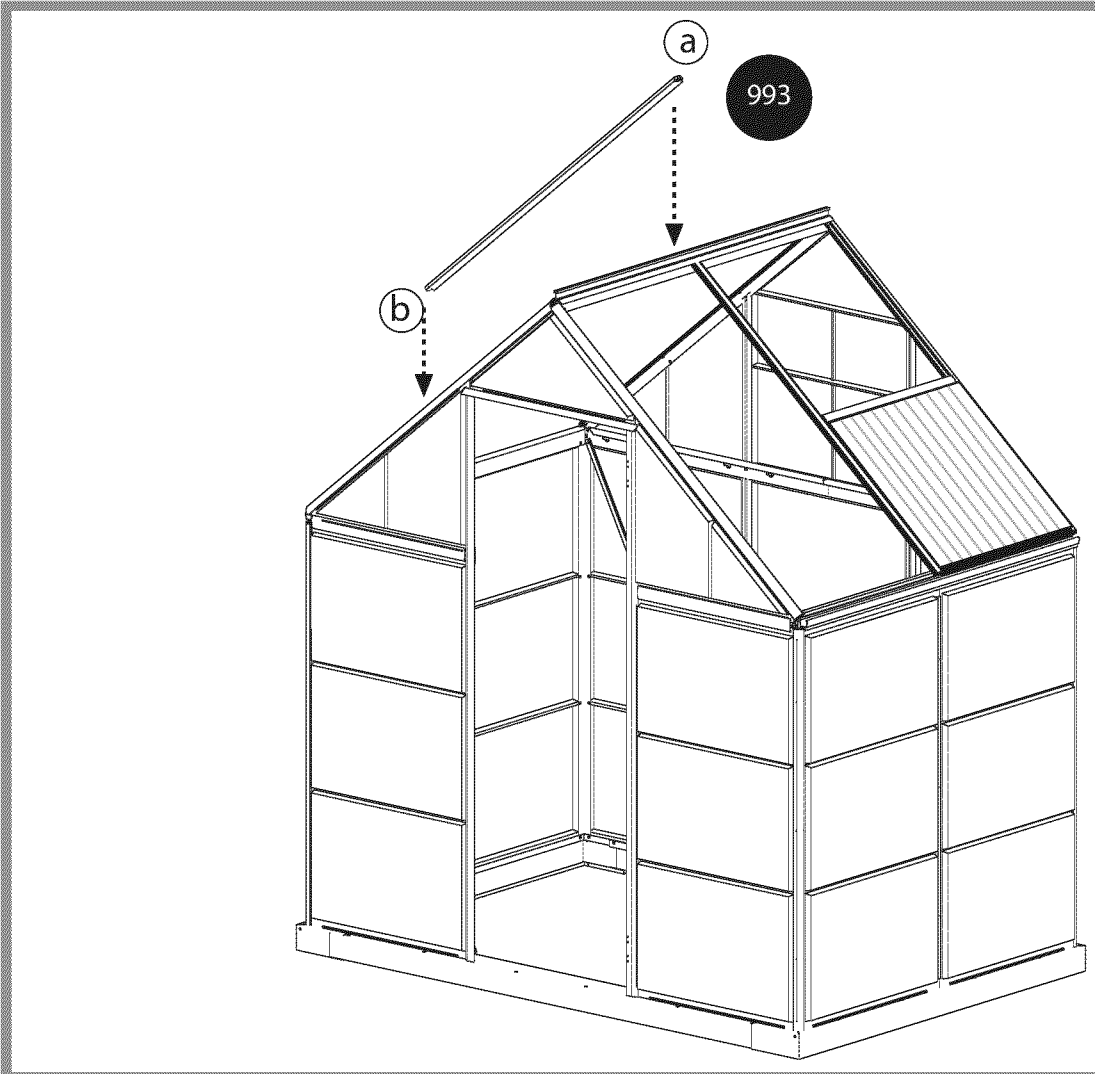
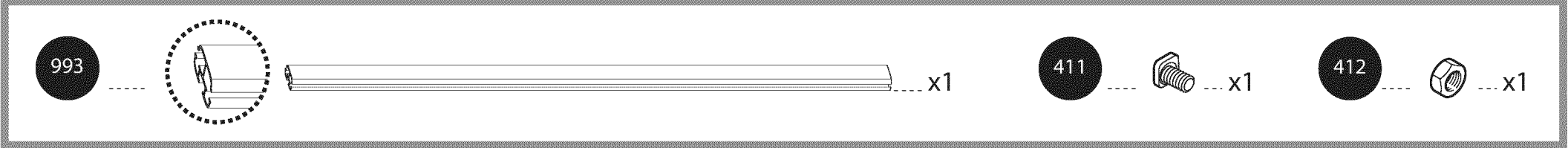
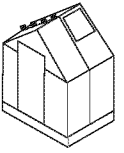

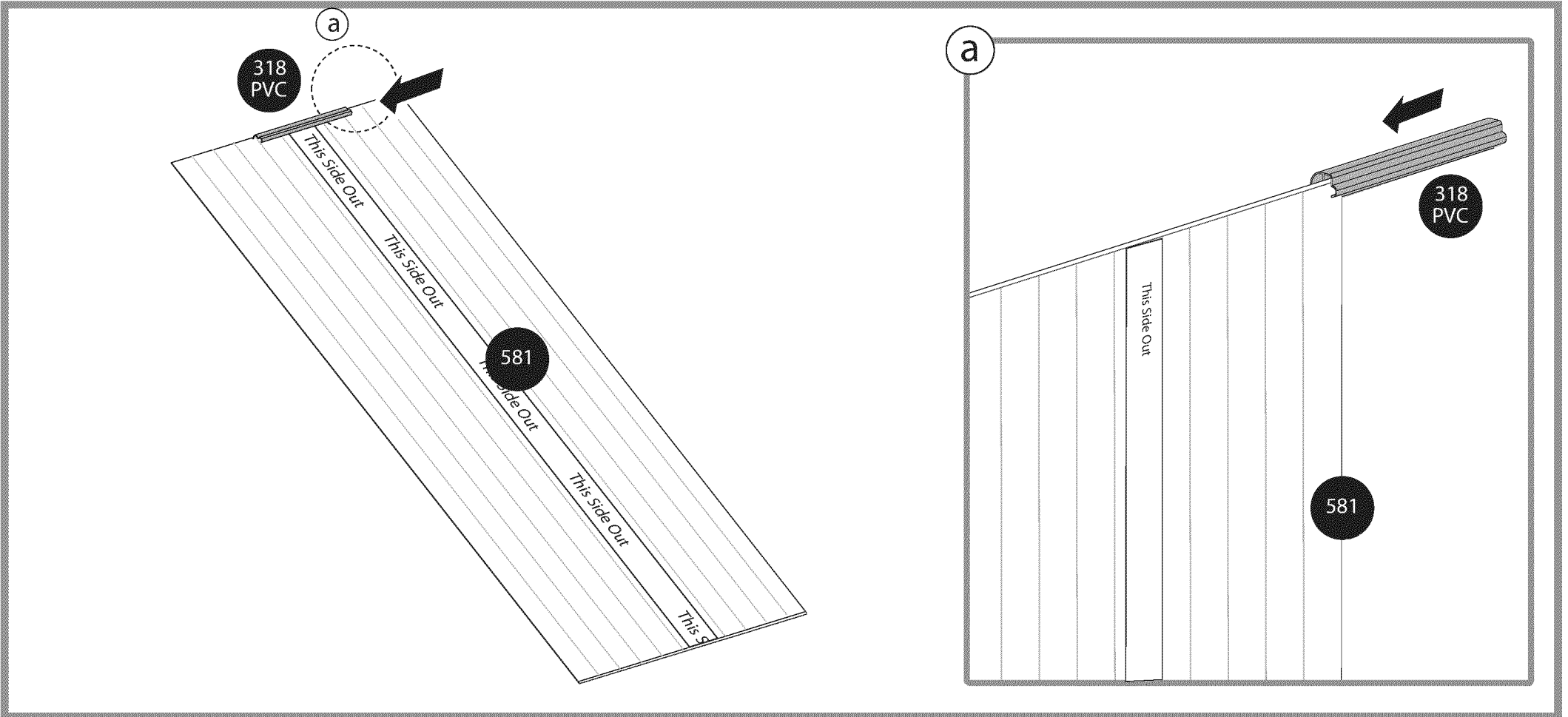
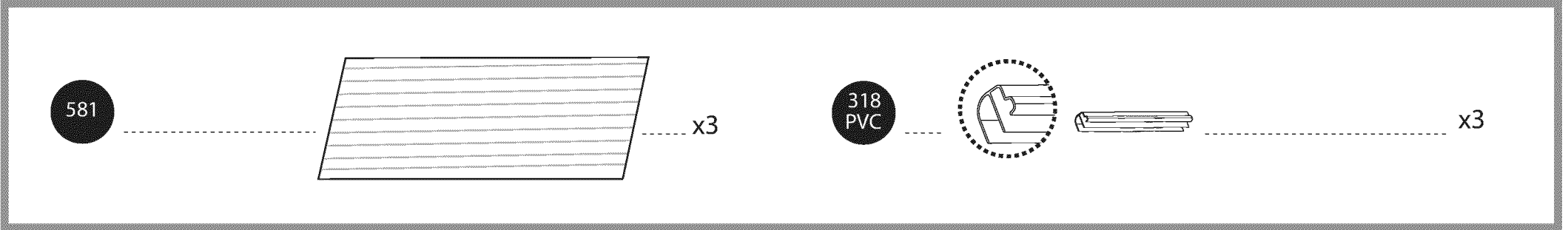
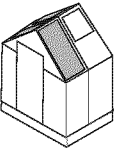

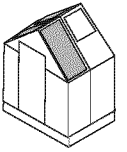

581

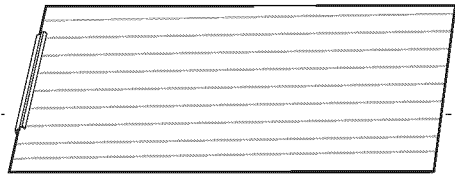

x1

981



x1

581

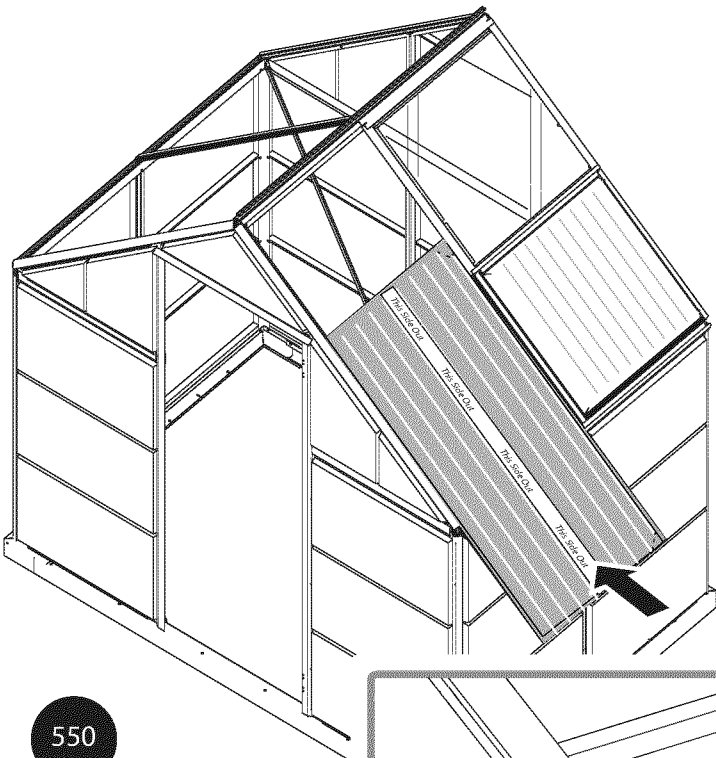

550

318
PVC

581

a

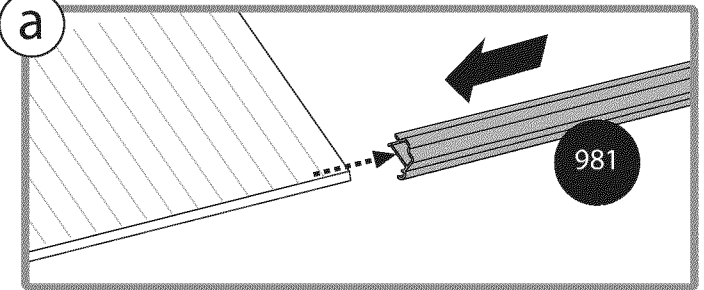

981

981

b

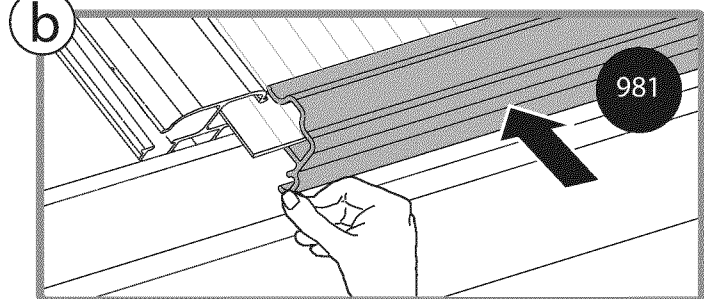

981

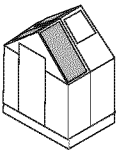

581

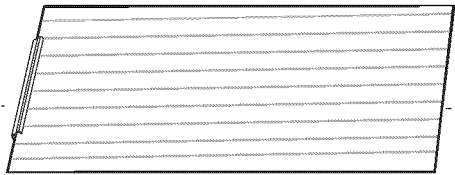

x2

981

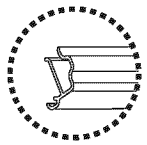

x2

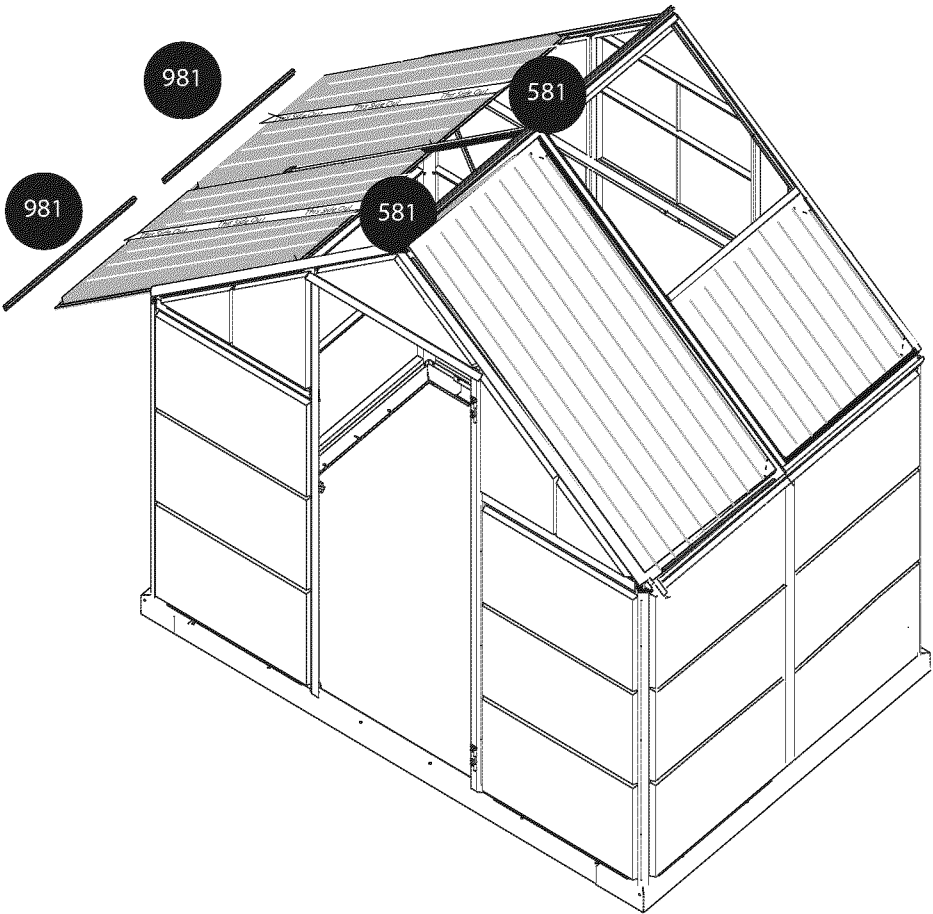

a

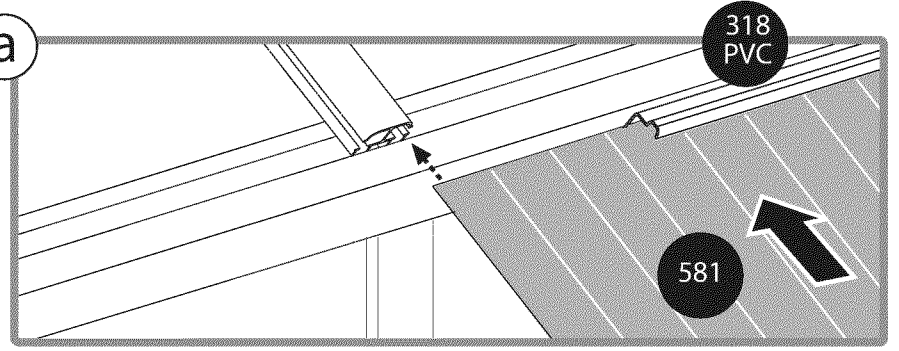

b

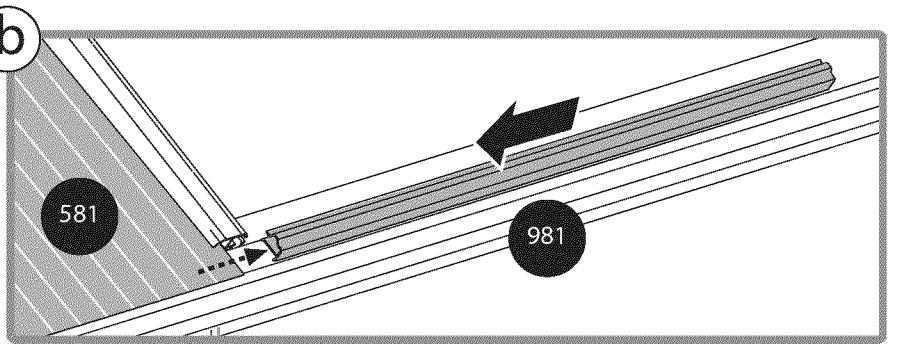

c

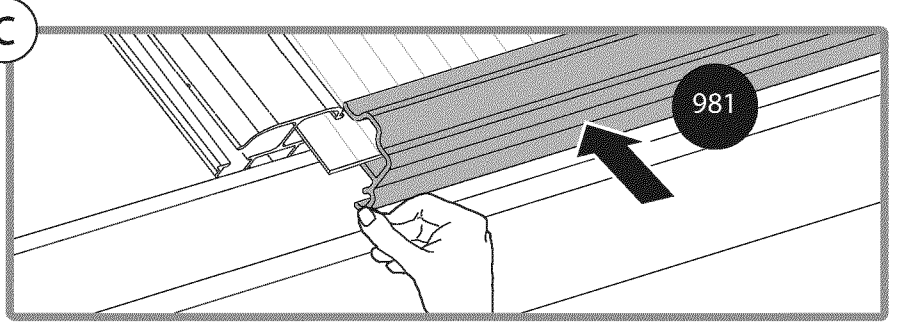

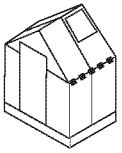

329

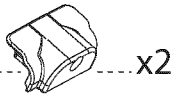

4043

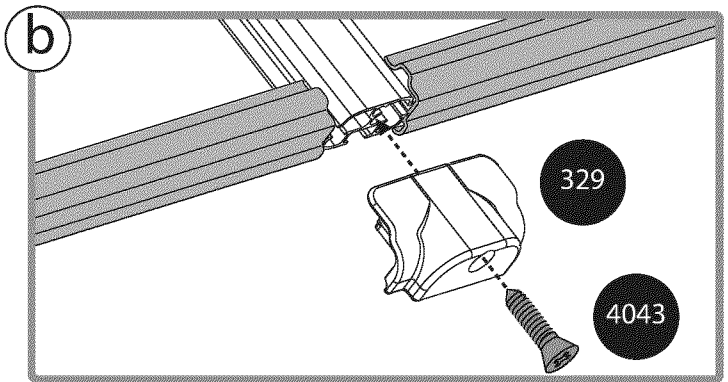
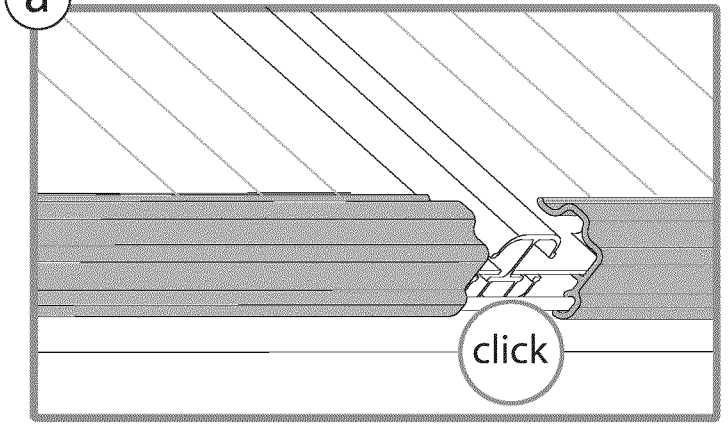
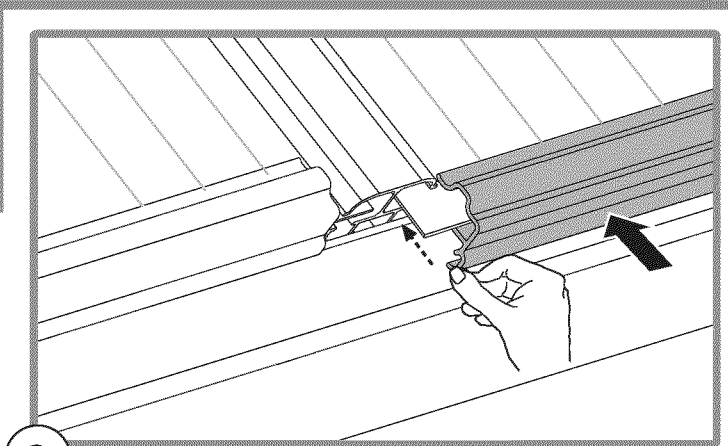
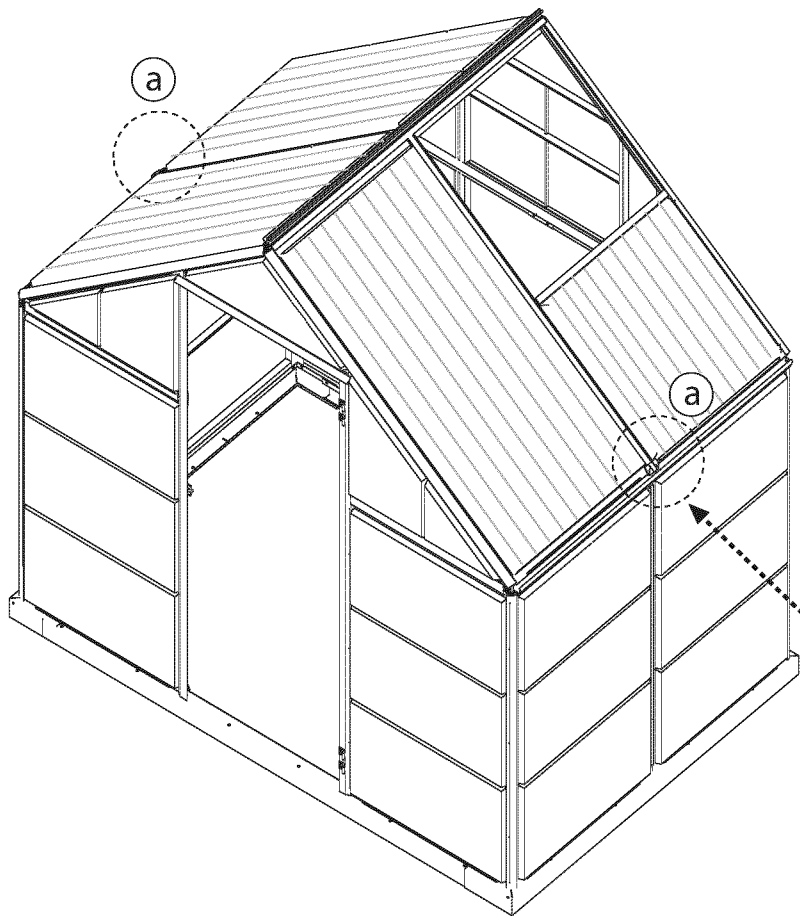

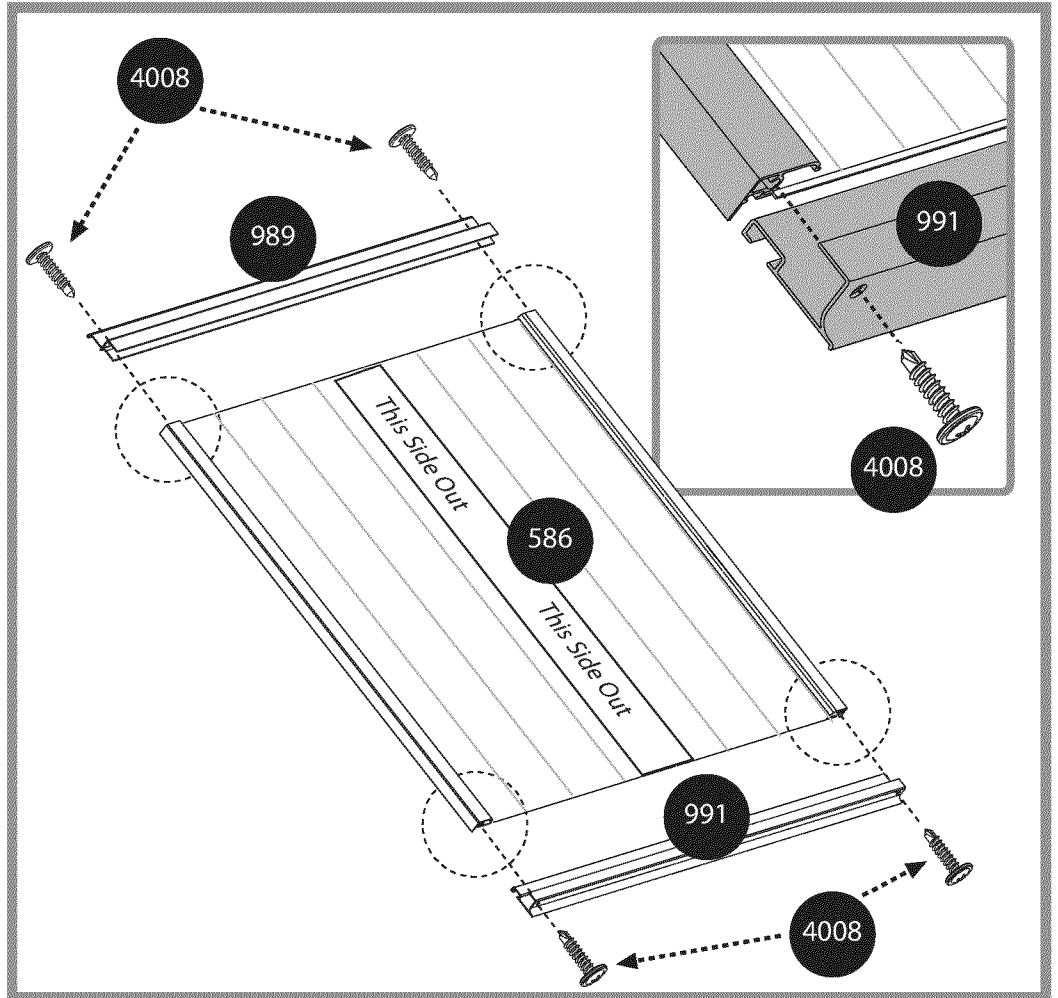
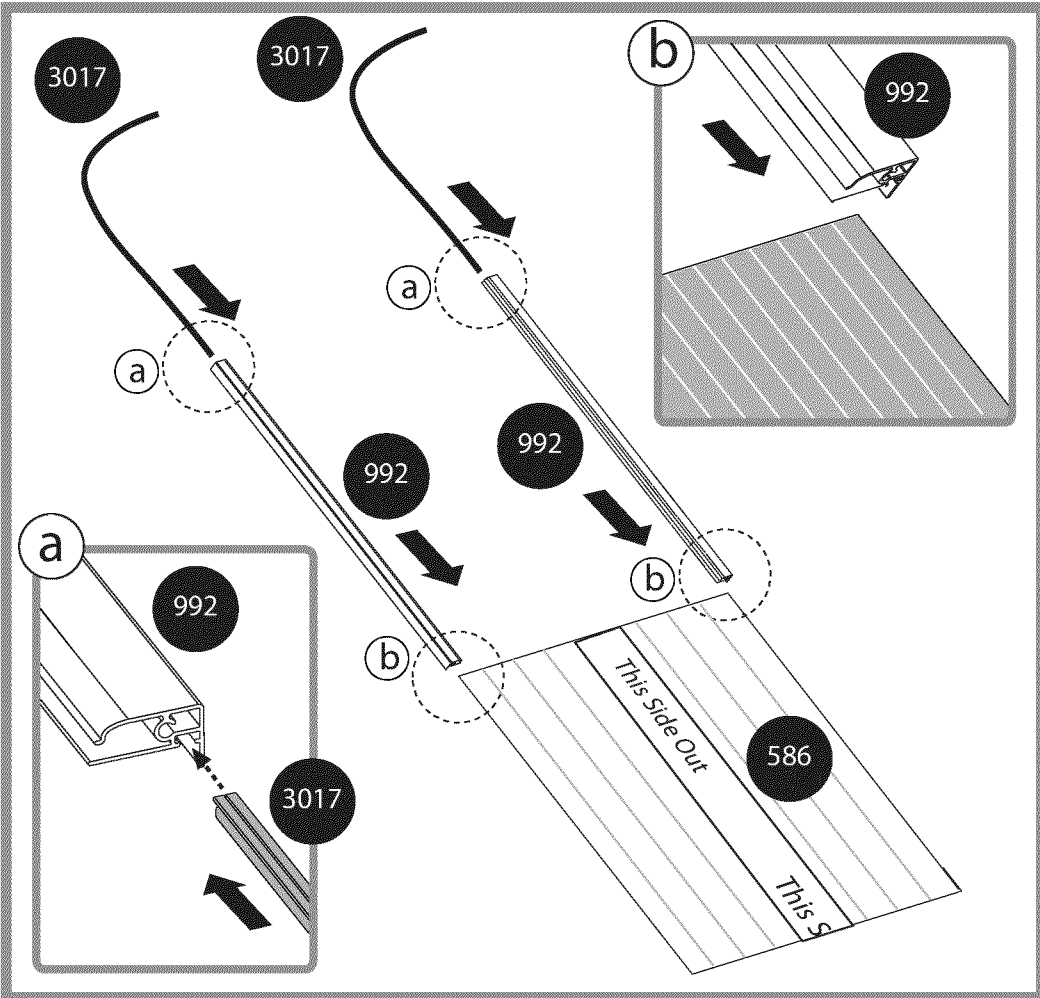
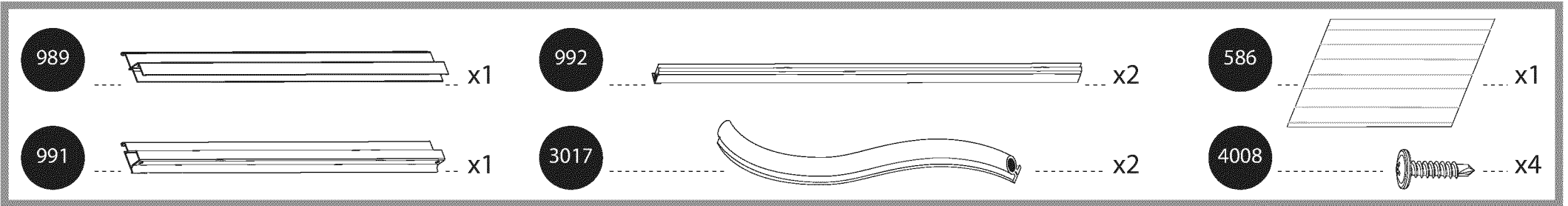
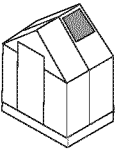

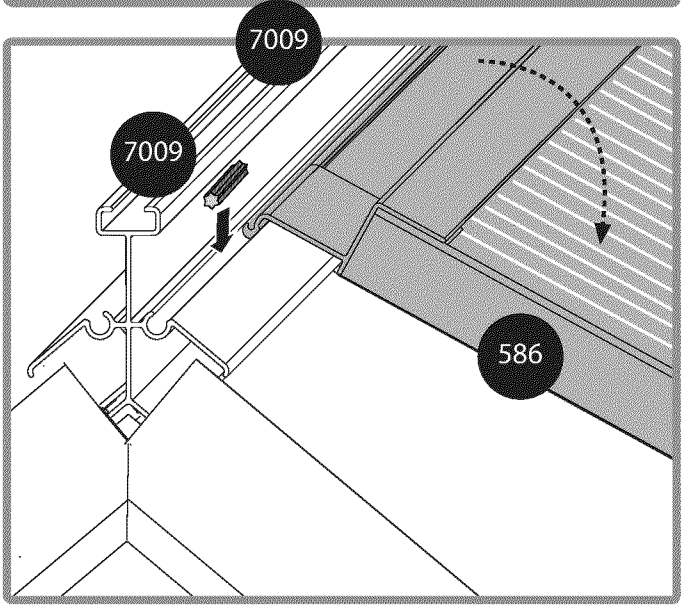
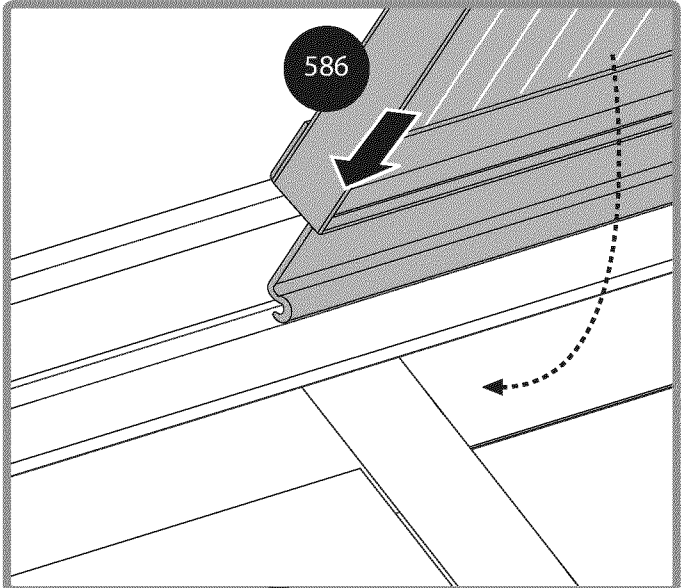
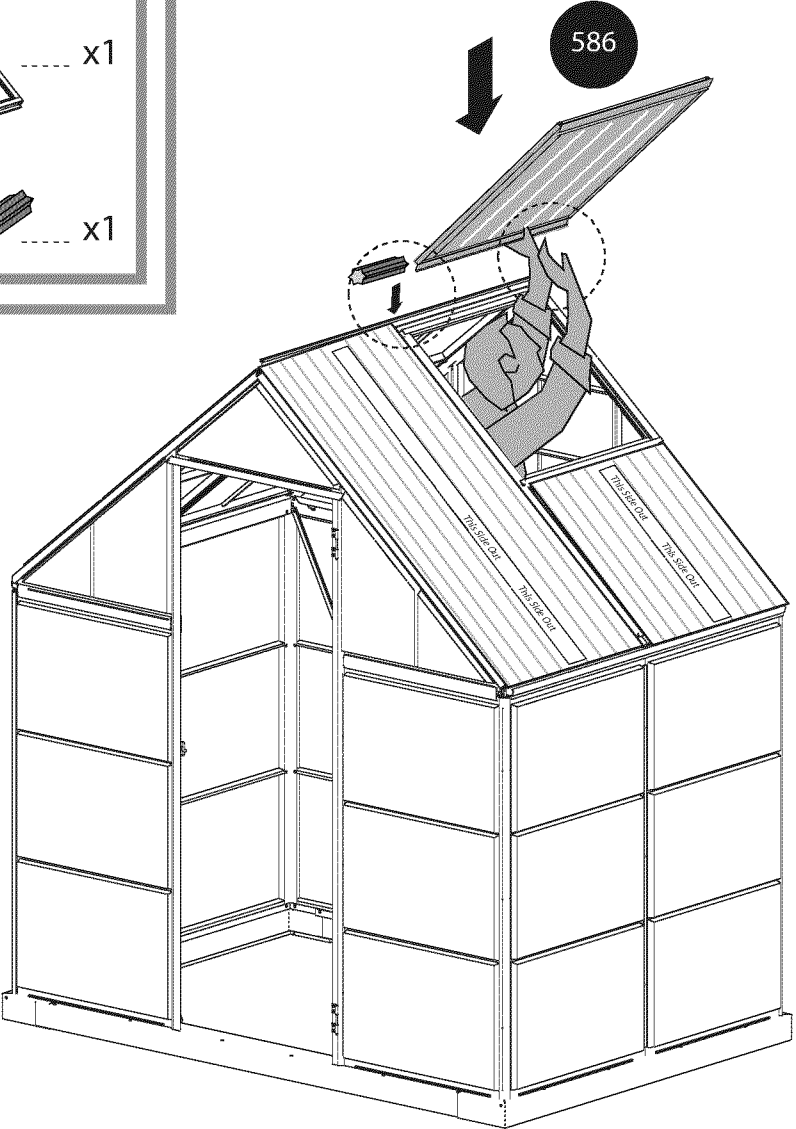
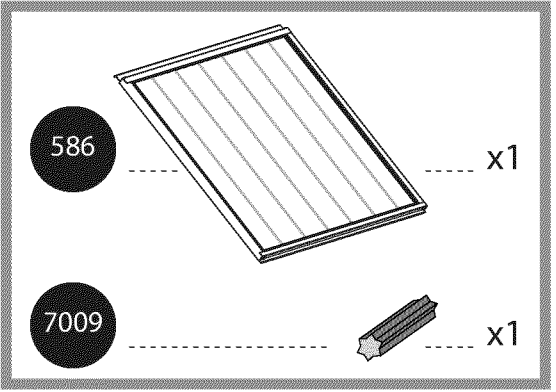
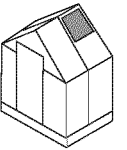

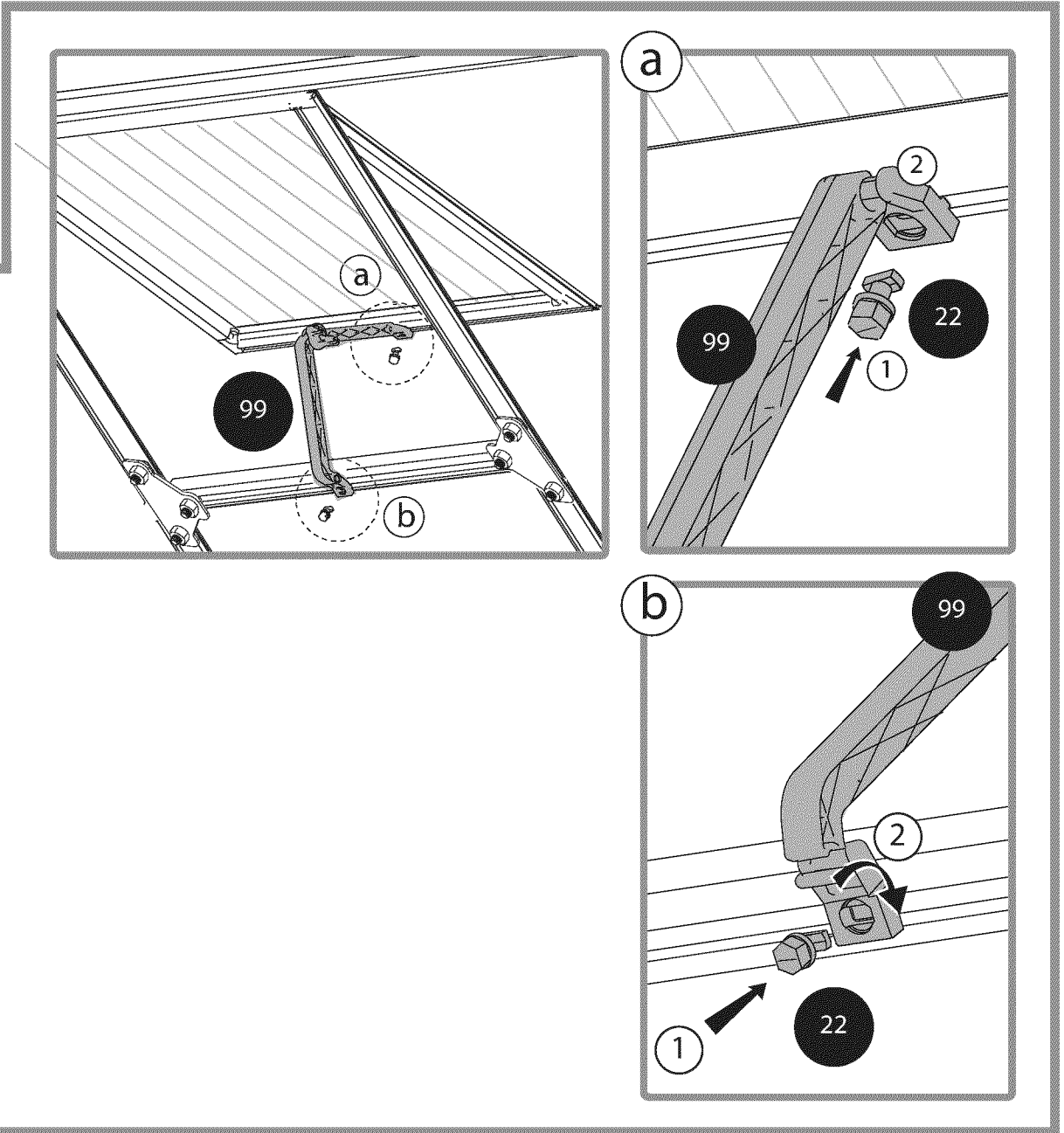
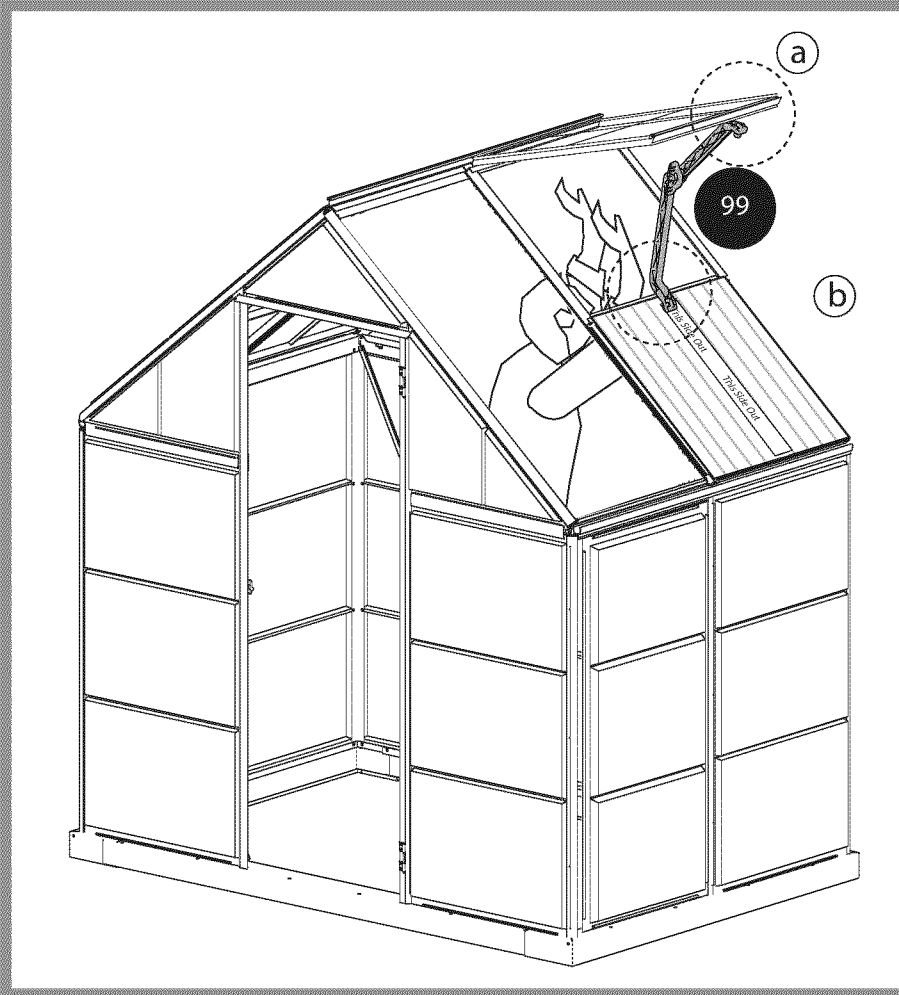
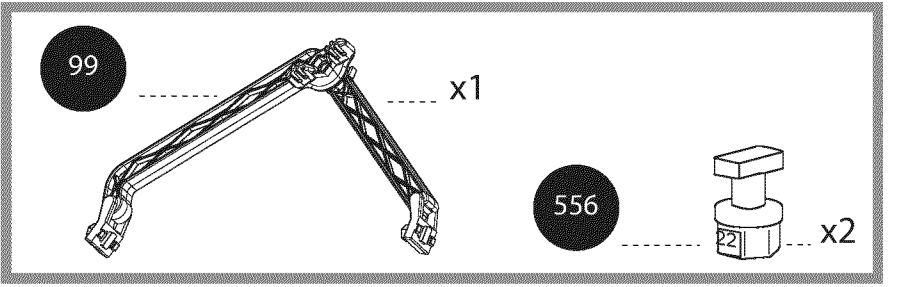
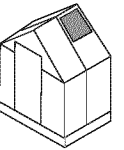

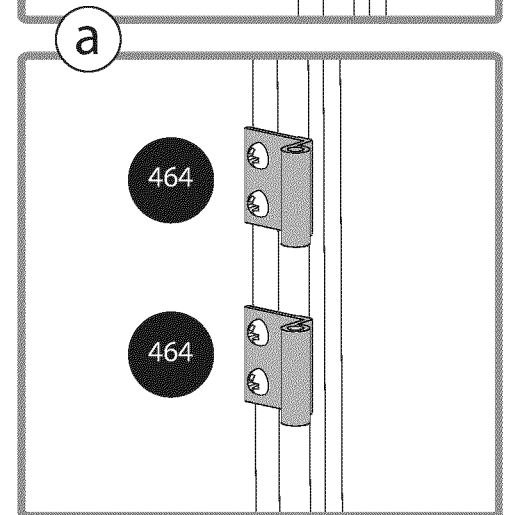
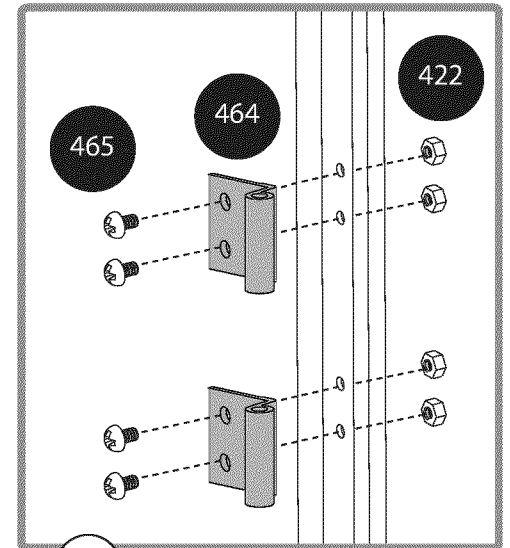
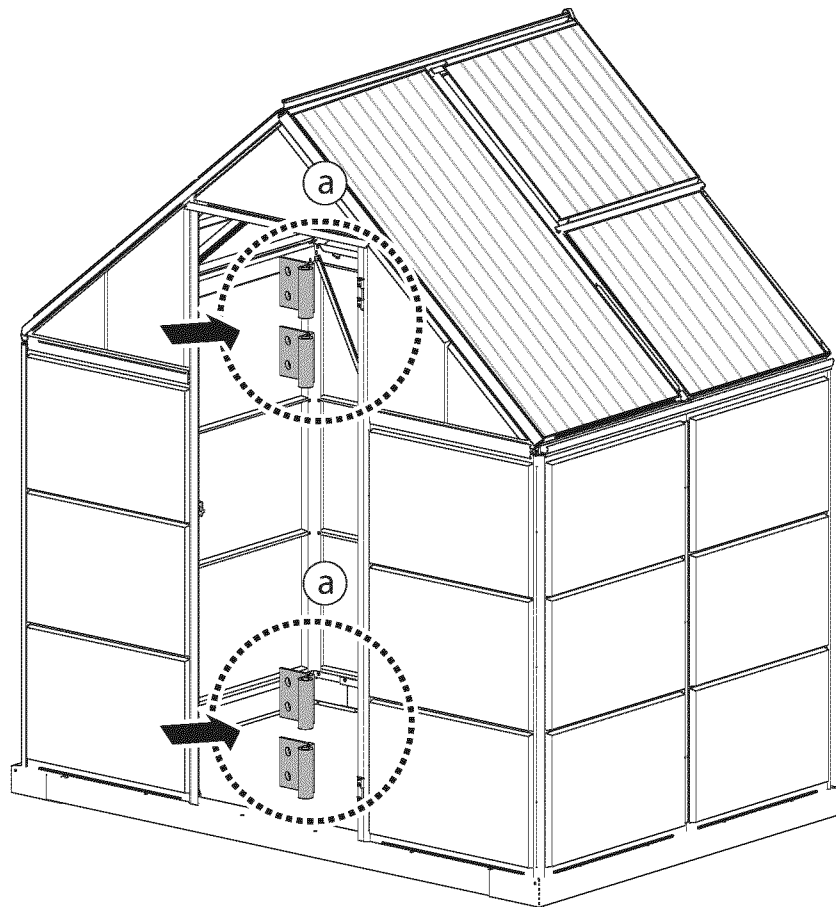
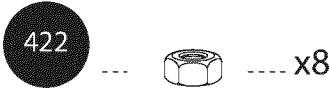
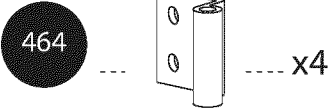
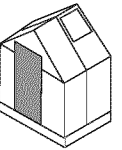

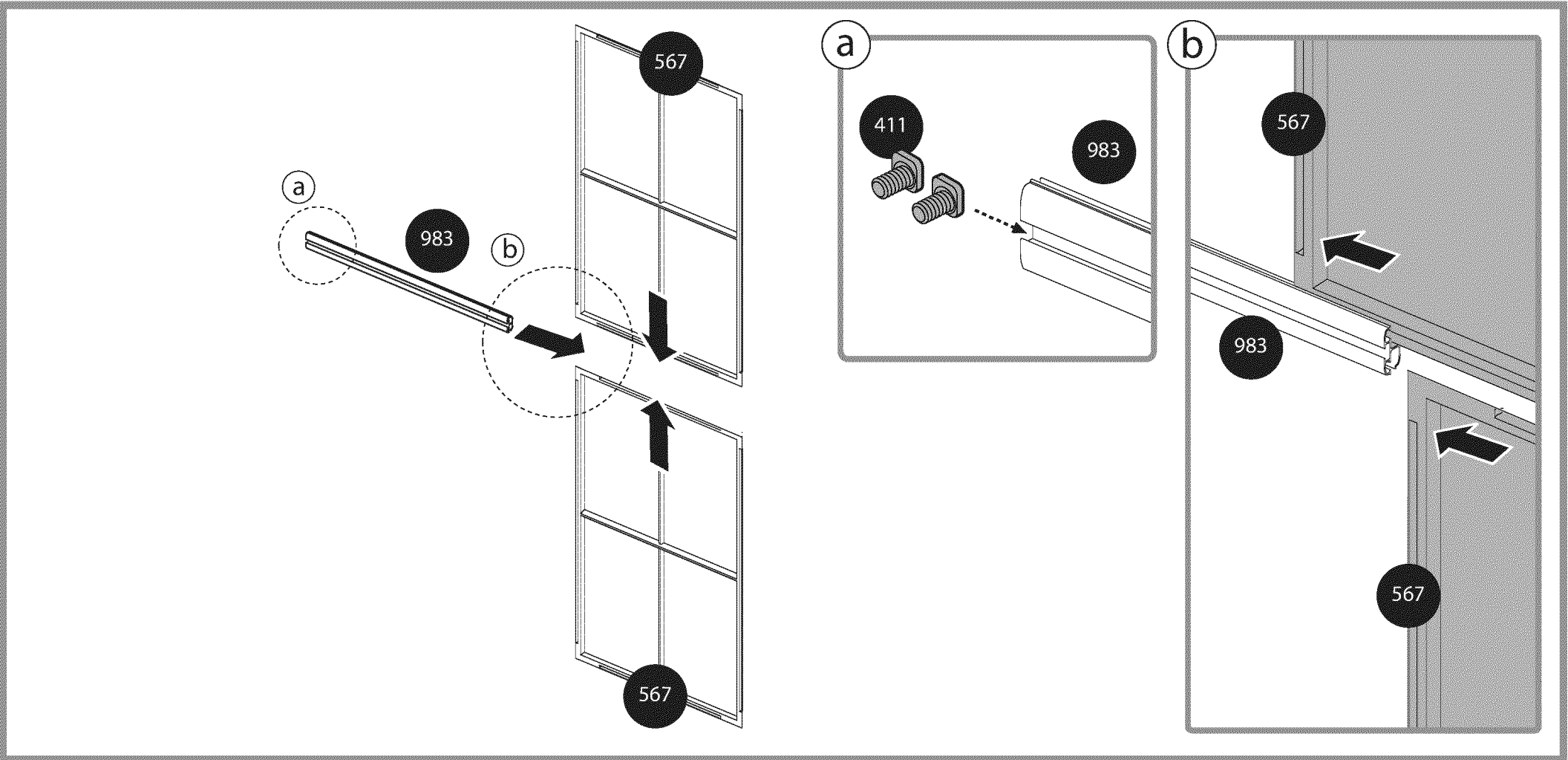
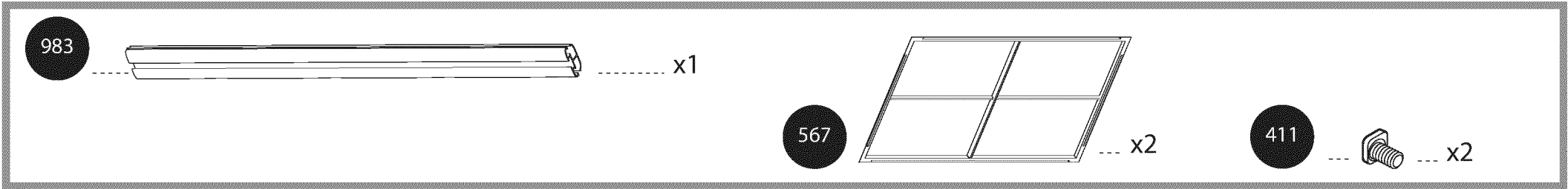
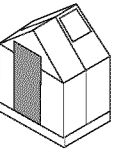

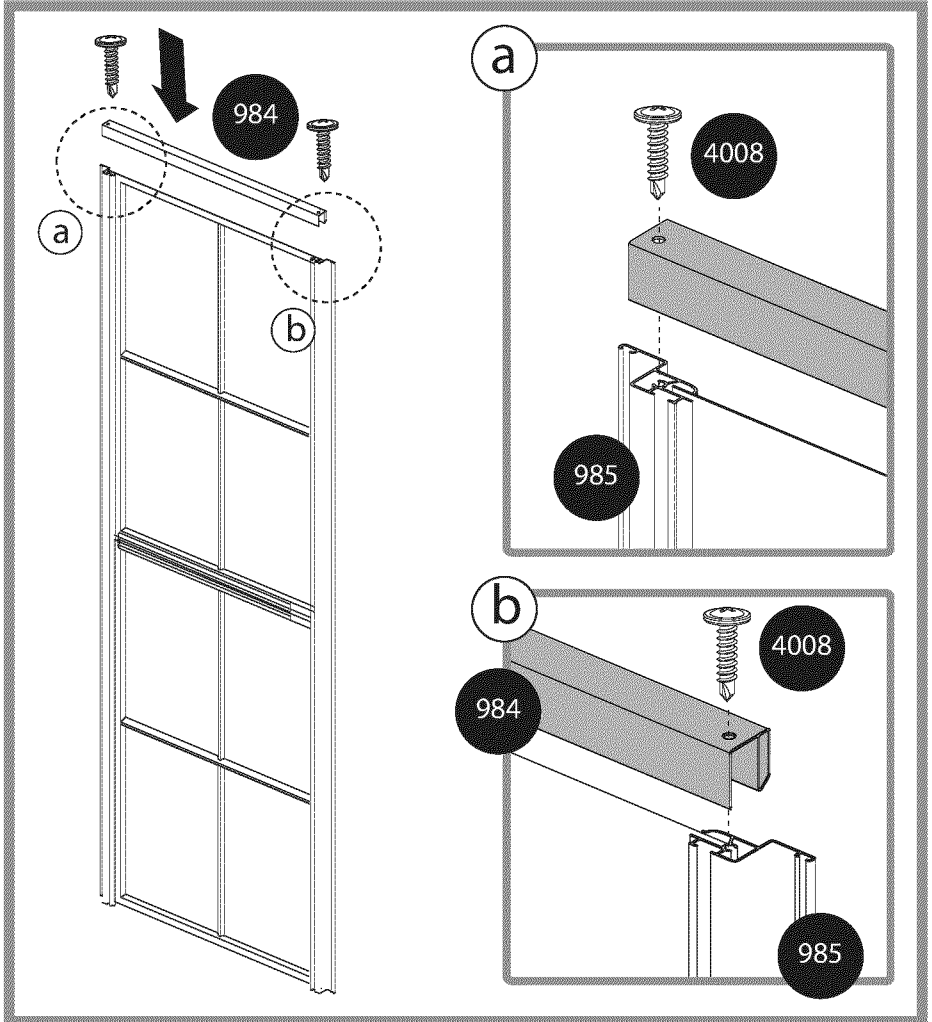
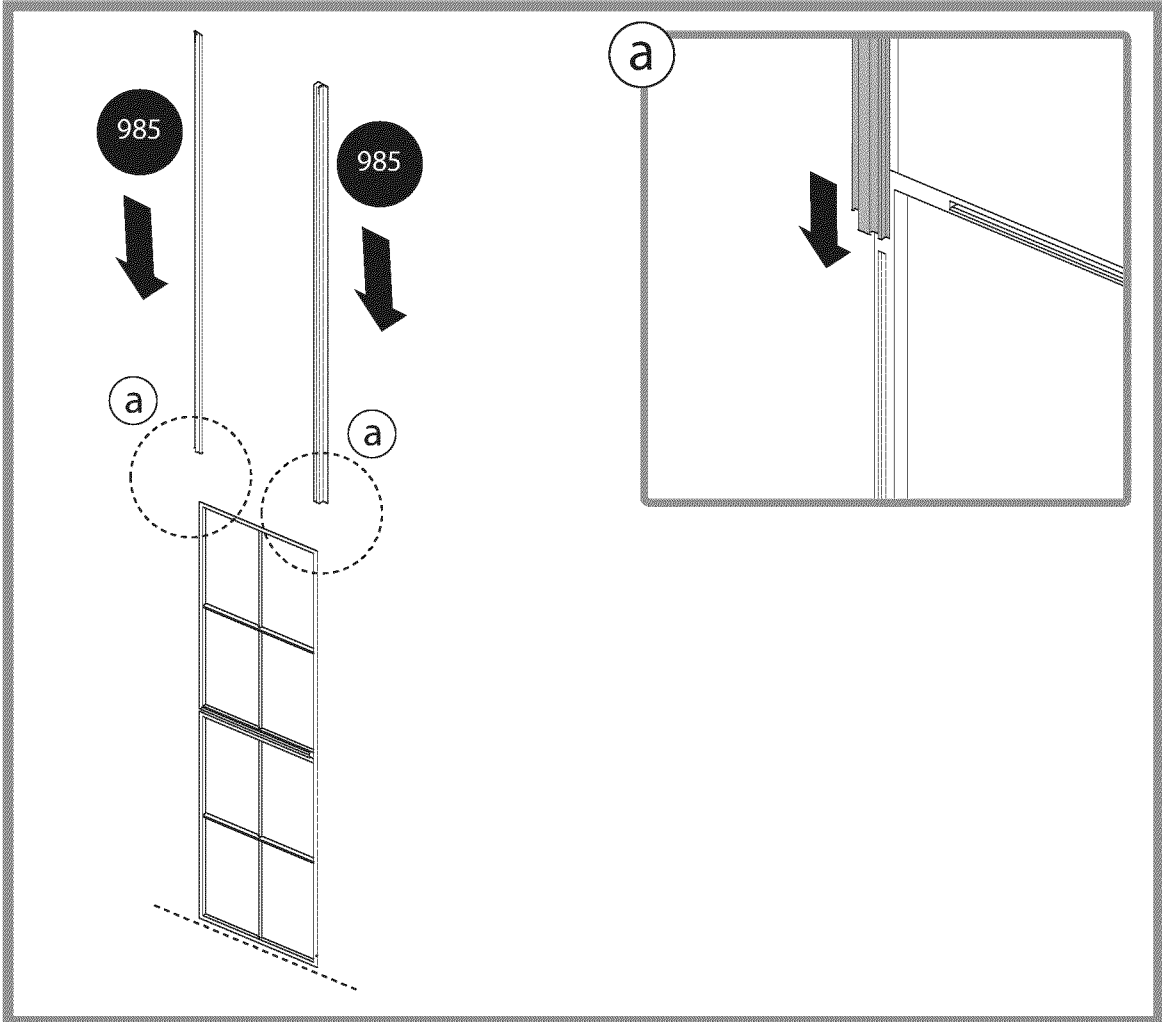
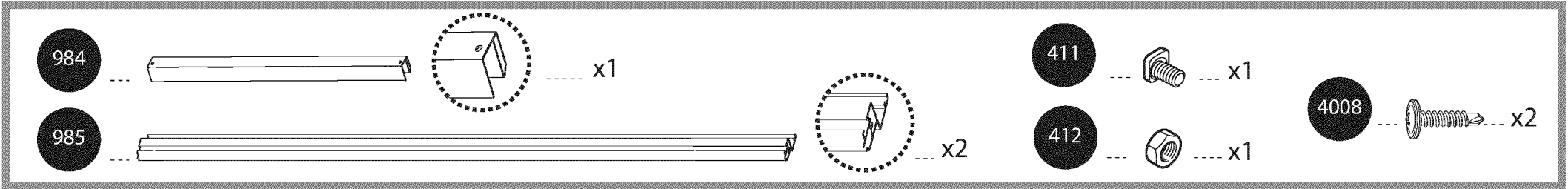
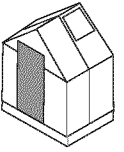

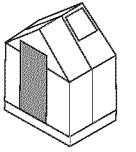

3016 x1

288 x1

412 x7

462 x2

411 x7

a

411 x6

b

411 x1

3016

412

462

288

412



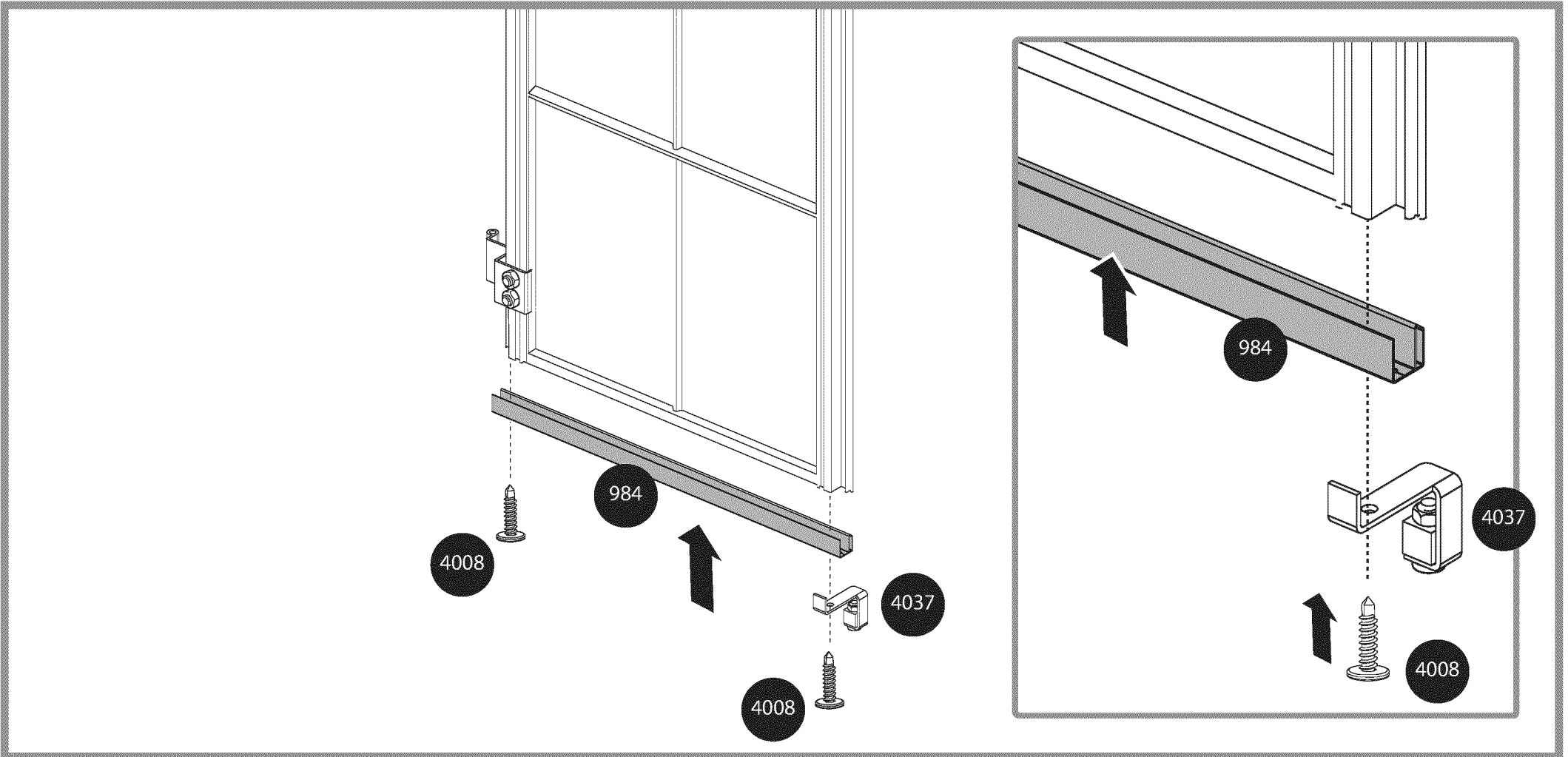
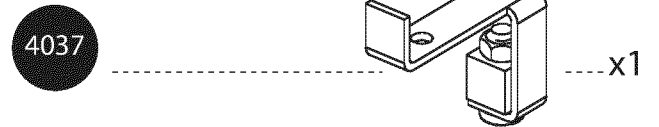
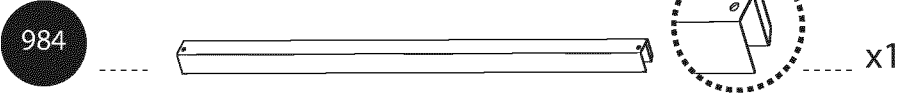
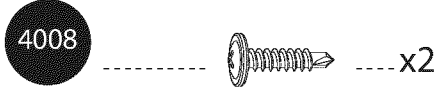
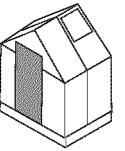

462

288

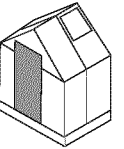
462

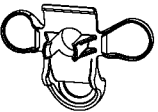
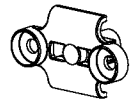
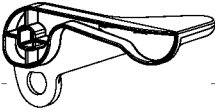
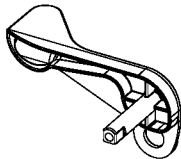



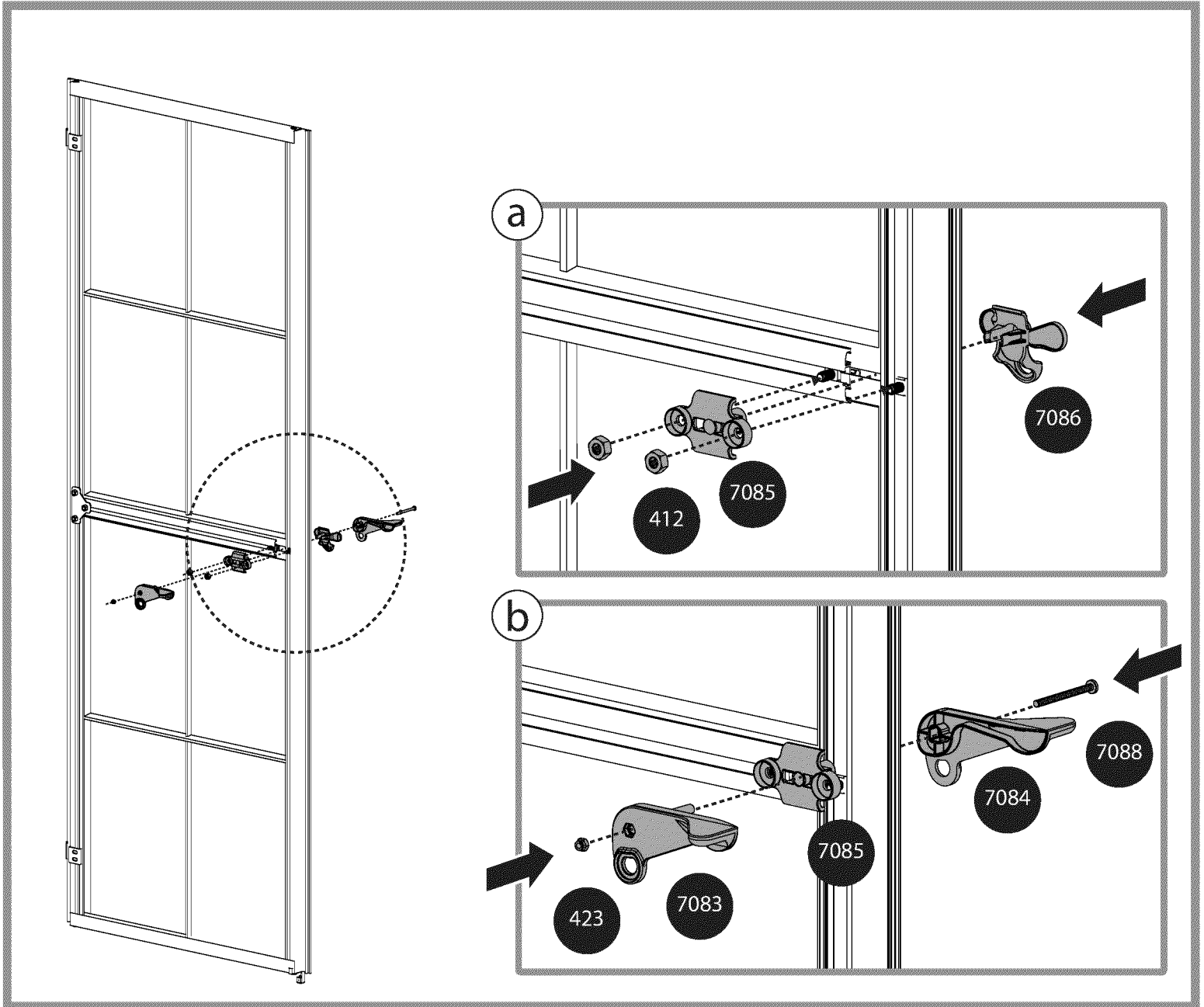

-  7086 x1
-  7085 x1
-  7084 x1
-  7083 x1
-  7088 x1
M4 x 50mm
-  423 x1
-  412 x2

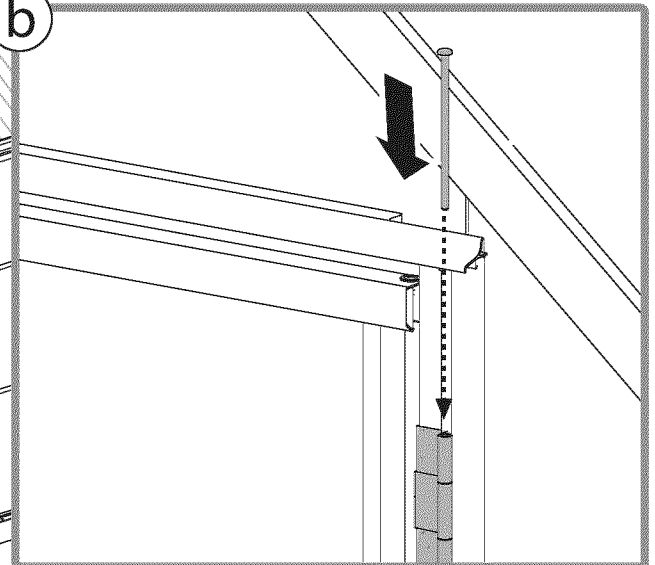
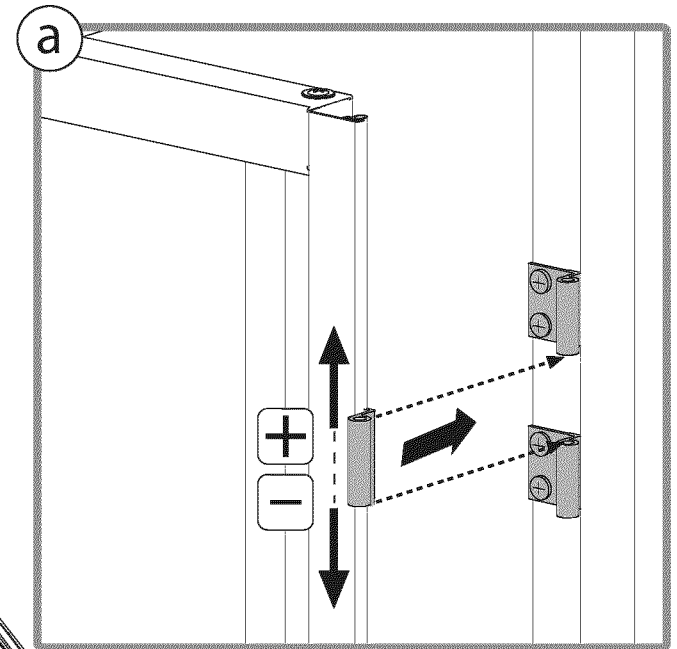
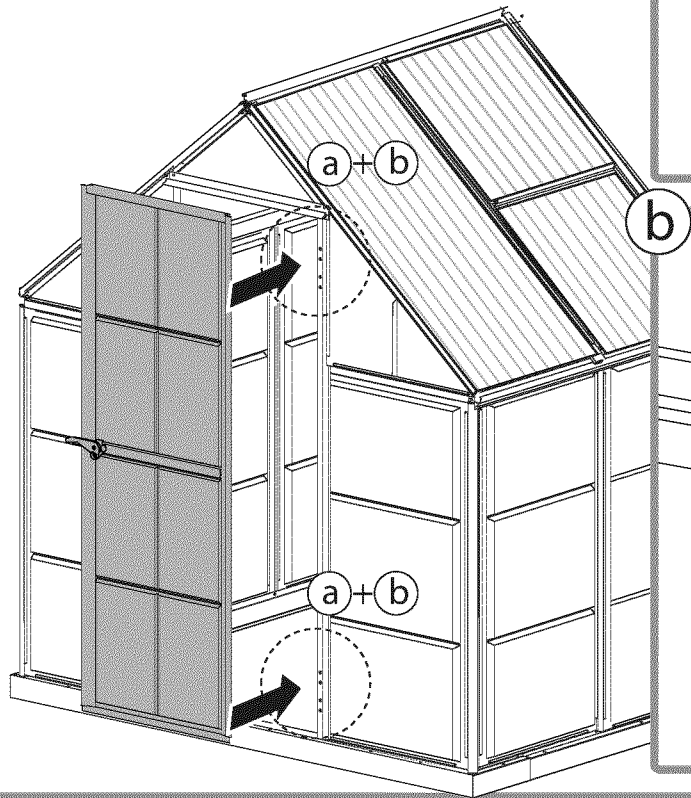
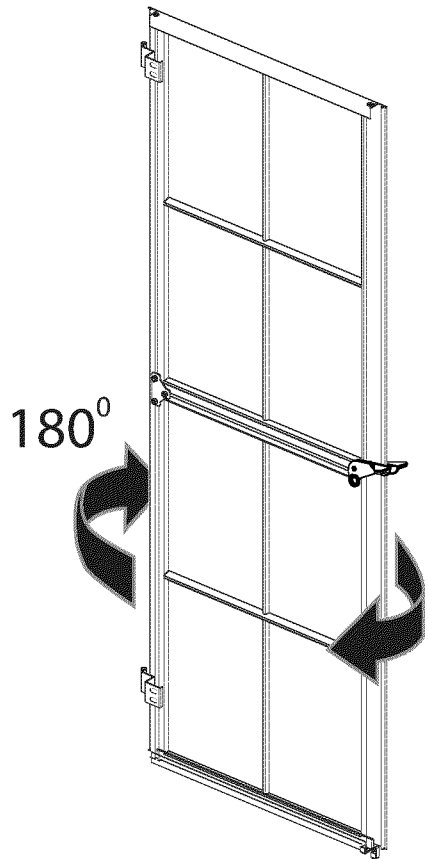
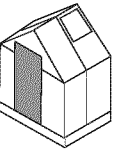

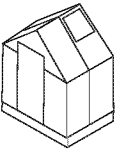

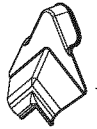

344L  x2 344R  x2 343  x2 447  x4

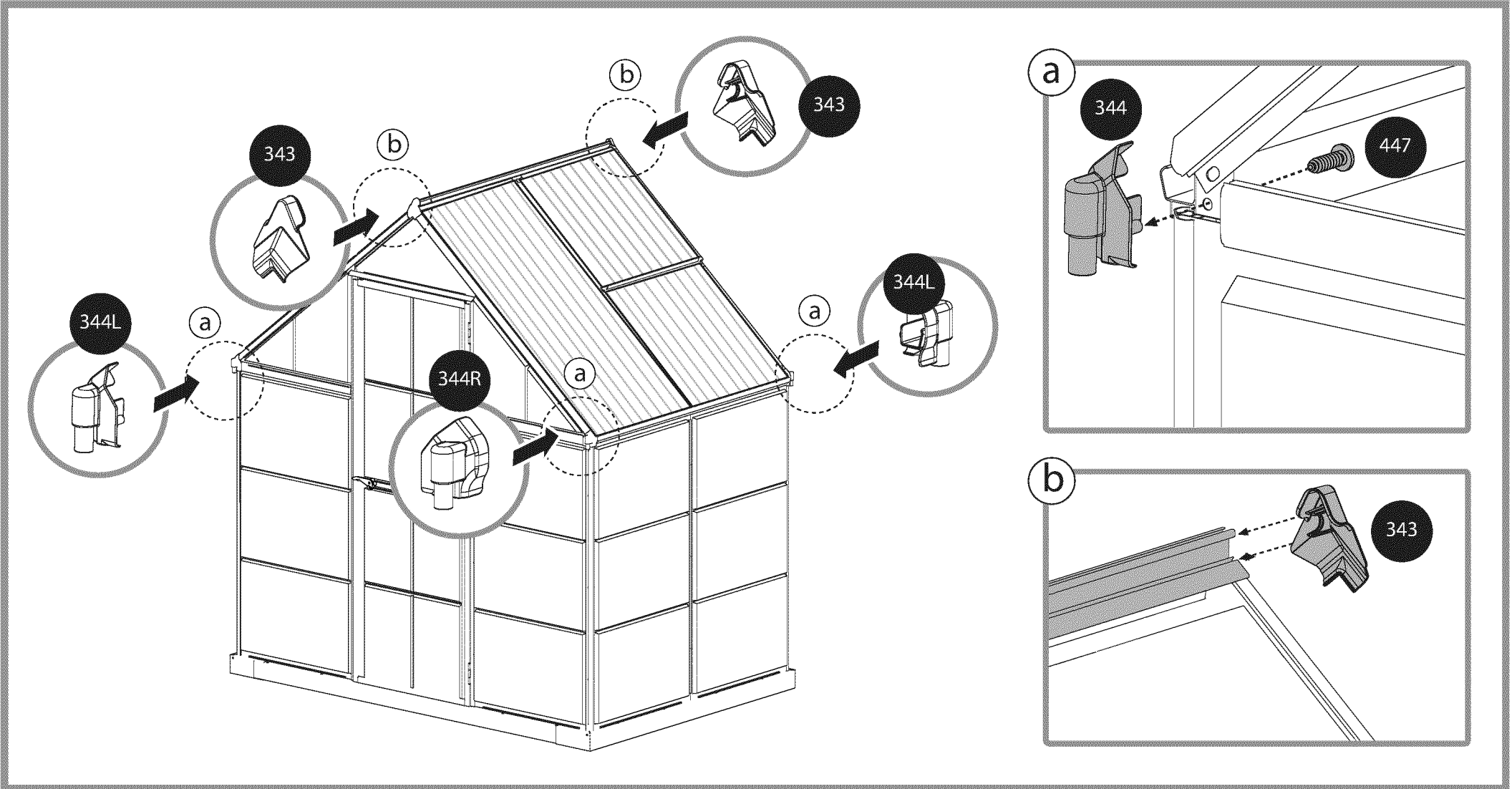

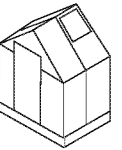

M96

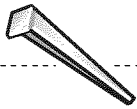

x4

P328

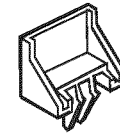

x18

